

# nPM2100 EK Hardware

## v0.9.0

User Guide

# Contents

Revision history	iv
Environmental and safety notices	v
<b>1 Introduction</b>	<b>7</b>
<b>2 Minimum requirements</b>	<b>9</b>
<b>3 Hardware description</b>	<b>10</b>
3.1 Block diagram	11
3.2 Power supply	12
3.2.1 Battery add-on boards	13
3.3 Output connections	13
3.3.1 Load switch and LDO	14
3.4 I/O pins	15
3.4.1 GPIOs	16
3.4.2 TWI	16
3.4.3 SHPHLD	17
3.4.4 PG/RESET	17
3.5 Jumpers and switches	17
3.5.1 VBAT slide switch	18
3.5.2 BOOST startup configuration	18
3.5.3 Load resistor selection	19
3.5.4 Reservoir capacitors	19
3.5.5 VEXT jumper	20
3.5.6 Boot monitor	20
3.6 Buttons	21
3.7 Battery capacity indicator	21
3.8 nPM Controller	21
<b>4 Connect and use the nPM2100 EK</b>	<b>23</b>
4.1 Use the nPM2100 EK with nPM PowerUP	23
4.2 Use the nPM2100 EK with the nRF54L15 DK	23
4.3 Use the nPM2100 EK with the nRF5340 DK	25
4.4 Use the nPM2100 EK with the nRF52840 DK	26
4.5 Use the nPM2100 EK with custom hardware	27
4.6 Use the nPM2100 EK with an alternative power source	27
<b>5 Current measurements</b>	<b>28</b>
5.1 Measure current profile with an oscilloscope	28
5.1.1 Measure VBAT, VEXT, and VOUT using an oscilloscope	29
5.2 Measure average current with an ampere meter	30
5.2.1 Measure VBAT, VEXT, and VOUT using an ampere meter	31
5.3 Use a Power Profiler Kit II for current measurements	31
Glossary	33
Recommended reading	34

Legal notices. . . . . 35

# Revision history

Date	Description
March 2025	First release

# Environmental and safety notices

Environmental and safety notices for the nPM2100 EK and power supply requirements.

## Skilled persons

The nPM2100 EK is intended for use only by skilled persons.

A skilled person is someone with relevant education or experience that enables them to identify potential hazards and takes appropriate action to reduce the risk of injury to themselves and others.



## Hot surface

In the event of a fault, touchable surfaces can heat up significantly.



## Electrostatic discharge

The nPM2100 EK is susceptible to *Electrostatic Discharge (ESD)*.

To avoid damage to your device, it should be used in an electrostatic free environment, such as a laboratory.



## Battery replacement

**Warning:** Due to the following safety concerns the battery in this product shall only be removed or replaced by qualified professionals:

- Replacing the battery with an incorrect battery type can cause a fire or explosion.
- Disposing the battery into a fire or hot oven, crushing it mechanically, or cutting it can cause an explosion.
- Leaving the battery in an environment with an extremely high temperature can cause an explosion or the leakage of flammable liquid or gas.
- Subjecting the battery to extremely low air pressure can cause an explosion or the leakage of flammable liquid or gas.

Pay attention to the polarity of the battery connectors on the battery add-on board. Connecting the polarity the wrong way causes the device to become hot and might cause irreversible damage to the EK.



**Environmental Protection**

Waste electrical products should not be disposed of with household waste.

Please recycle where facilities exist. Check with your local authority or retailer for recycling advice.

**Note:** This equipment is not suitable for use in locations where children are likely to be present.

# 1 Introduction

The nPM2100 *Evaluation Kit (EK)* is a hardware platform used to evaluate the nPM2100 *Power Management Integrated Circuit (PMIC)*.

## Key features

- Battery connector with possibility to connect a variety of battery add-on boards (PCA63567)
- Easy connection through male pin headers and probe loops to measure PMIC voltage inputs and outputs
- Onboard nPM Controller (host SoC) to configure PMIC with nPM PowerUP
- USB powered *Low-Dropout Regulator (LDO)* to enable the evaluation of nPM2100 by supplying selectable voltage levels without the need for a battery
- No hardware changes needed for measuring key parameters
- Power supply selection from VBAT or VEXT using slide switch
- Equipped with jumpers to perform the following tasks:
  - Selection of VOUT startup voltage level (VSET)
  - Configuration of reservoir capacitor size
  - Configuration of load switch/LDO
  - Enabling or disabling of the boot monitor
  - Configuration of VEXT output voltage from the onboard LDO
- Plug-and-play connection to nPM PowerUP, which is a computer app that enables quick evaluation and implementation of Nordic PMICs
- Evaluation without writing code or performing any device programming when using with nPM PowerUP
- Use with a Nordic *Development Kit (DK)* to develop your own nPM2100 application
- Use with your own custom hardware to develop your own nPM2100 application

## nPM2100 PMIC

- Ultra-efficient boost regulator delivering up to 150 mA
- 50 mA load switch/LDO supplied by the boost regulator
- 35 nA Ship mode with multiple wakeup options
- 175 nA Hibernate mode with wakeup timer
- Fuel gauge for primary cell batteries

## nPM PowerUP

- Computer application to simplify evaluation and implementation of Nordic PMIC applications
- Ability to configure, evaluate, and export all PMIC settings
- Intuitive user experience for a seamless hardware-firmware-software solution
- Available for download from [nRF Connect for Desktop](#)

## Kit content

The nPM2100 EK includes hardware and access to software components, hardware design files, and documentation.

The nPM2100 EK comes with premounted jumpers and battery add-on boards.

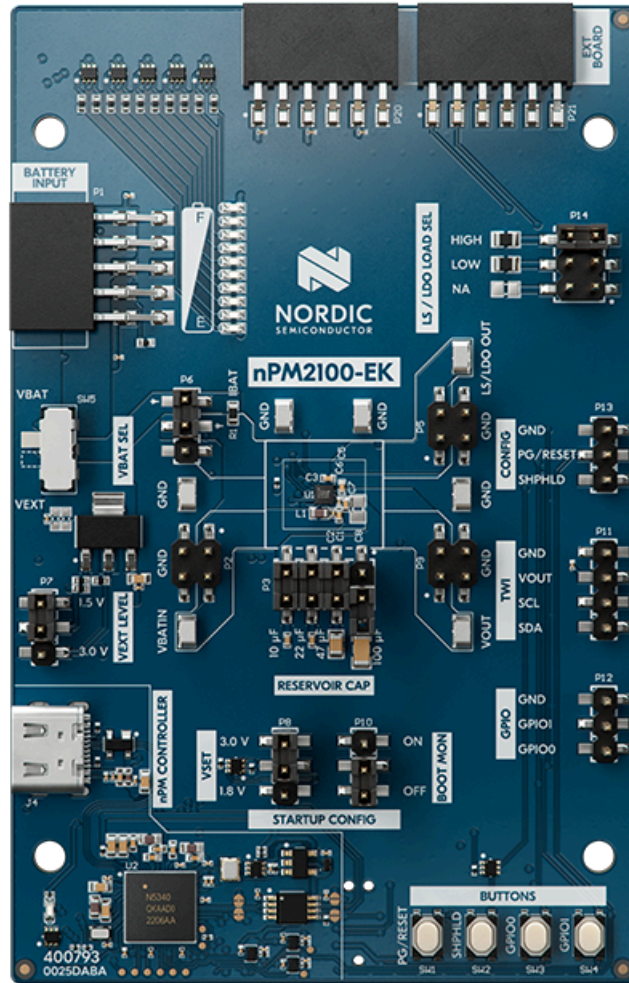

Figure 1: nPM2100 EK board (PCA10170)

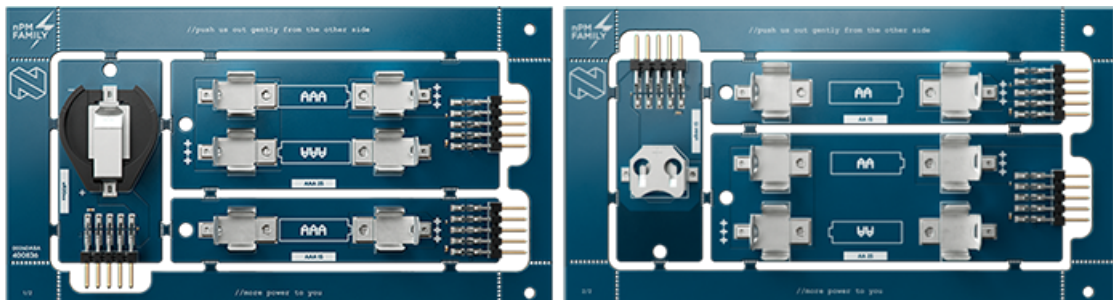

Figure 2: nPM2100 EK battery add-on boards (PCA63567)

The hardware design files including schematics, PCB layout files, bill of materials, and Gerber files for the nPM2100 EK are available on the nPM2100 EK product page.

# 2 Minimum requirements

Before you start, check that you have the required hardware and software.

## Hardware requirements

- USB Type-C
- 2.54 mm (0.1 inch) pitch wires for connecting the nPM2100 EK with a Nordic *DK* or your own device
- Batteries for evaluating nPM2100 features

## Software requirements

- nPM PowerUP available from [nRF Connect for Desktop](#)

# 3 Hardware description

The nPM2100 EK enables the evaluation of different functions and features of the nPM2100 PMIC without extra programming. It allows full configuration flexibility without requiring hardware modifications.

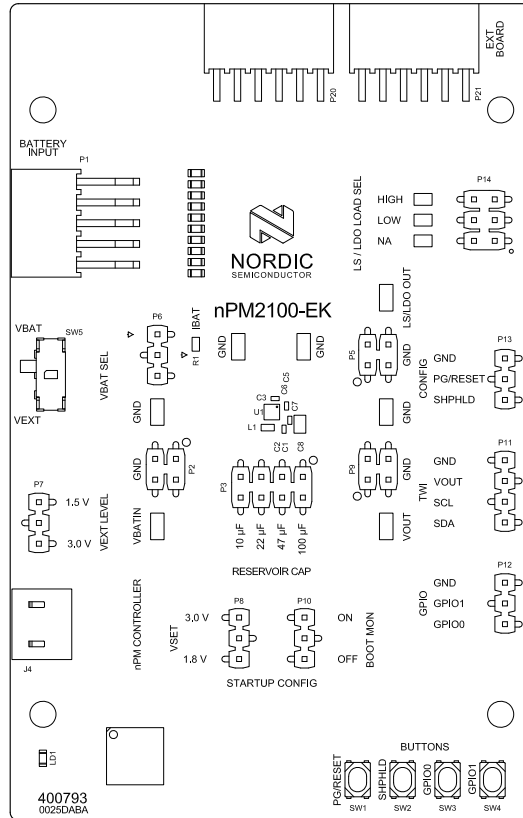

Figure 3: nPM2100 EK front view

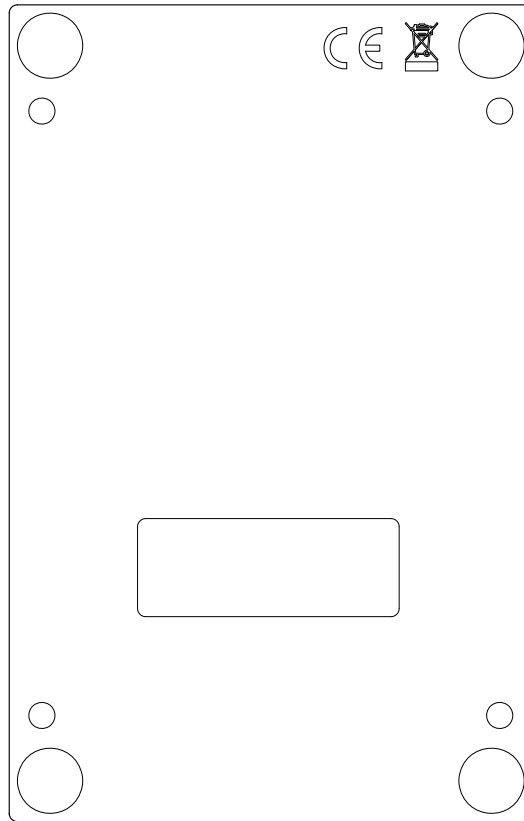

Figure 4: nPM2100 EK back view

### 3.1 Block diagram

The block diagram illustrates the nPM2100 EK functional architecture.

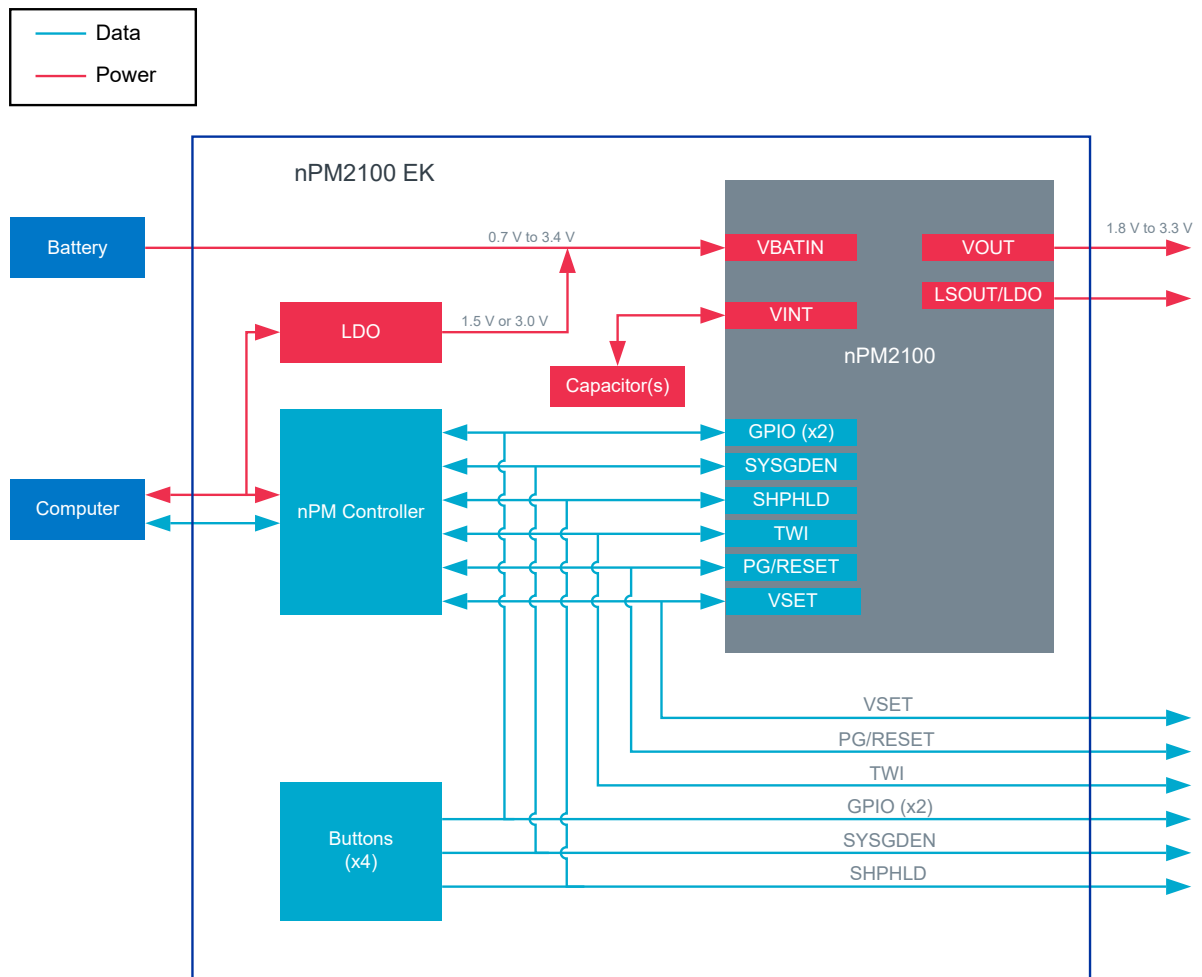

Figure 5: Block diagram

## 3.2 Power supply

The nPM2100 EK can be powered by USB or a battery using the battery add-on board. The USB supplies the nPM2100 PMIC through an LDO, with selectable voltages of 1.5 V or 3.0 V, that can be configured with a jumper.

The LDO enables evaluation of the nPM2100 PMIC by supplying selectable voltage levels without the need for a battery. Connecting a compatible battery to the EK allows for the evaluation of the nPM2100 features in an environment similar to a custom application. For more information on selecting the power supply, see [VBAT slide switch](#) on page 18.

The following figure shows the power supply options for the EK.

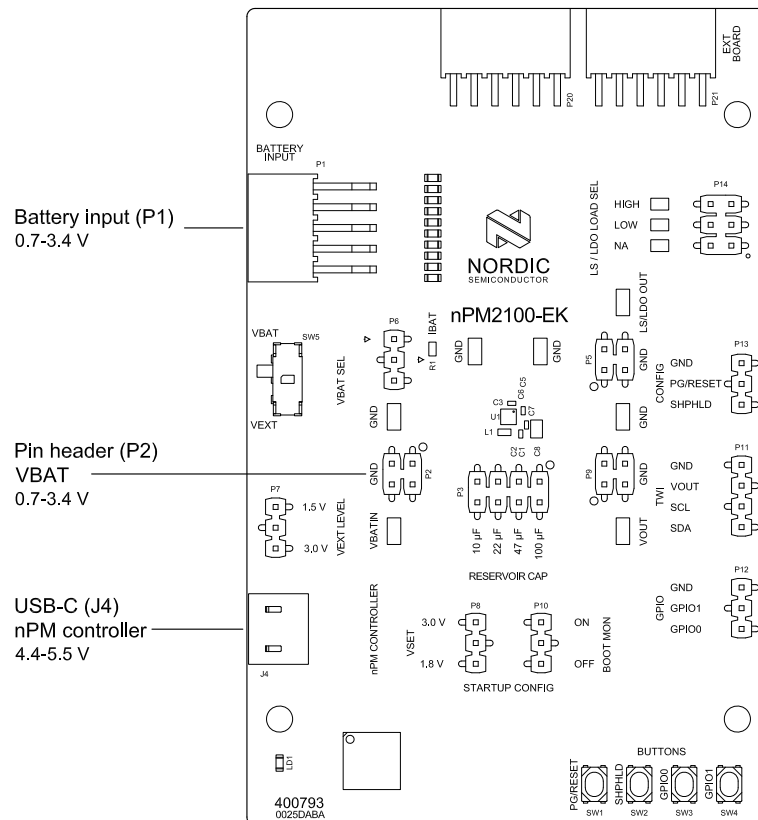

Figure 6: Power supply

The following table shows the connection of the battery source to the EK.

Input source		Part	Connector type	Comment
Battery	VBAT	<b>P1</b>	Pin socket	<b>VBAT</b> on pins 1 and 3
	0.7 V to 3.4 V	<b>P2</b>	Pin header	<b>VBAT</b> on pins 1 and 2

Table 1: Options for connecting power input sources

### 3.2.1 Battery add-on boards

There are six separate battery add-on boards that can be used with the nPM2100 EK. These boards support one-cell xR20xx, xR44, and AA/AAA, and two-cell AA/AAA batteries. The xR20xx holder accommodates all 20 mm batteries.

**Note:** Break out the individual battery add-on boards using pliers.

**Warning:** Pay attention to the polarity of the battery connectors on the battery add-on board. Connecting the polarity the wrong way causes the device to become hot and might cause irreversible damage to the EK.

## 3.3 Output connections

The nPM2100 boost regulator output (**VOUT**) is accessible on the EK through pin headers and probe loops.

The connection options are the following:

- Pin headers – use to power other devices like the nRF54L15 DK or a custom design.
- Probe loops – use to test the performance of the nPM2100 PMIC using lab equipment like an electronic load, Source Measure Unit (SMU), oscilloscope, or the Power Profiler Kit II (PPK2).

In addition, the load switch or LDO regulator output is available on pin header P5. For more information, see [Load switch and LDO](#) on page 14.

The following figure shows the pin headers and probe loops for the power outputs on the EK.

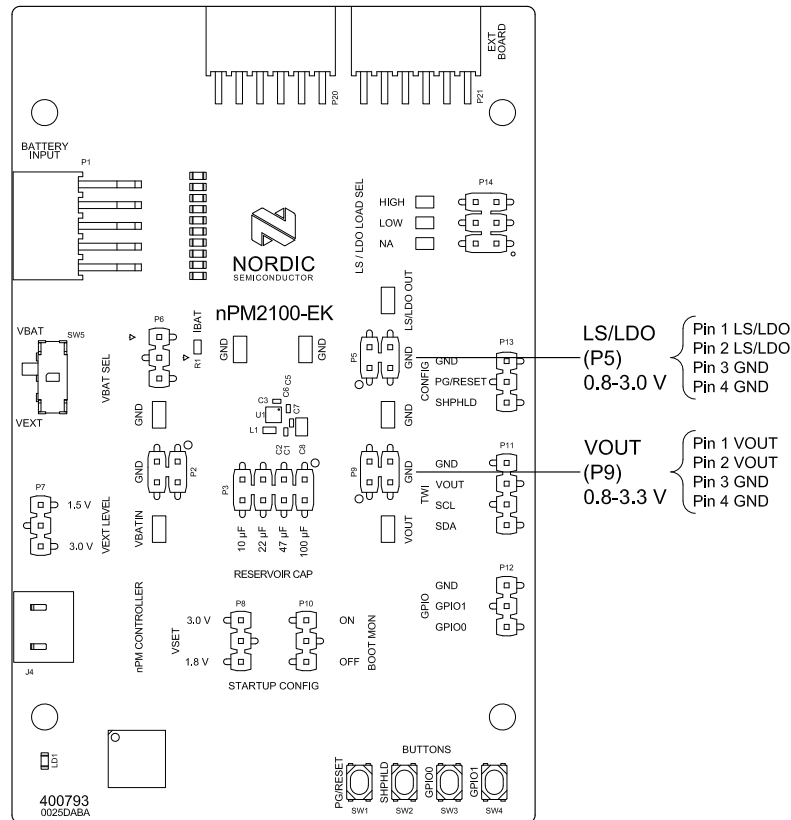

Figure 7: Pin headers and probe loops for power outputs

### 3.3.1 Load switch and LDO

The load switch or LDO is available on pin header P5.

The following figure and table show the schematic and function descriptions for the load switch and LDO.

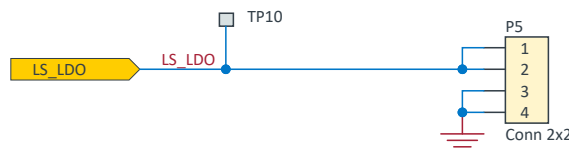

Figure 8: LSOUT/VOU TLDO schematic

Pin	Pin name	Function
1	LSOUT/VOU <sub>T</sub> LDO	Load switch or LDO output
2	LSOUT/VOU <sub>T</sub> LDO	Load switch or LDO output
3	GND	Ground
4	GND	Ground

Table 2: Load switch and LDO header description

### 3.4 I/O pins

The nPM2100 EK provides connections to status and control pins of the nPM2100 *PMIC*, including two GPIOs available for custom workflows.

All status and control pins on the *PMIC* are accessible on pin headers. For default configuration of the EK, see [Jumpers and switches](#) on page 17.

The following table and figure show the I/O pin headers on the EK.

Pin header	I/O
P11	TWI
P12	GPIO
P13	SHPHLD PG/RESET

Table 3: I/O pin headers

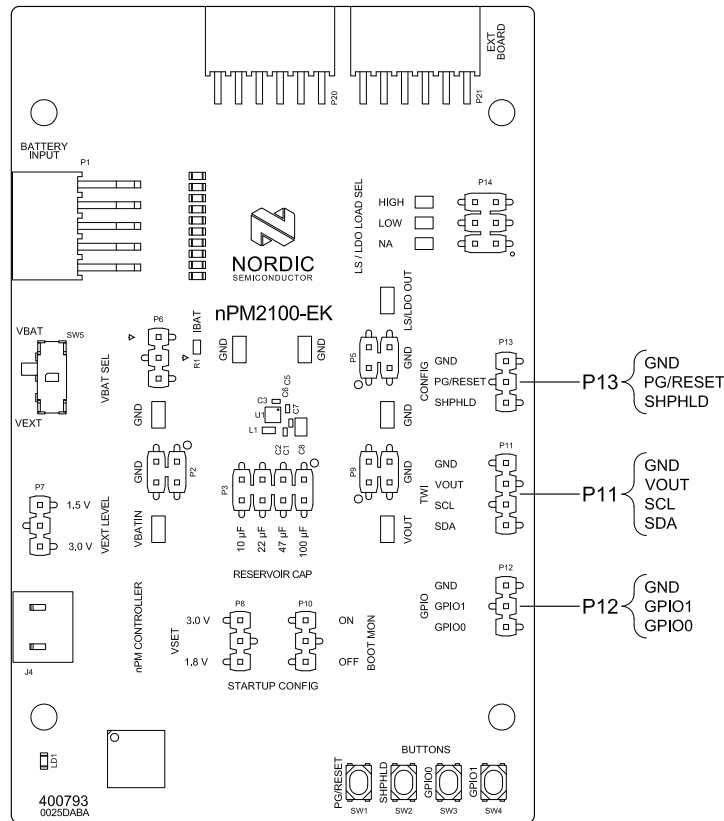

Figure 9: I/O pin headers

### 3.4.1 GPIOs

Two GPIOs are available on pin header **P12**. The GPIOs can be configured using nPM PowerUP.

All GPIOs are inputs with weak pull-down by default.

The following figure and table show the schematic and function descriptions for the GPIOs.

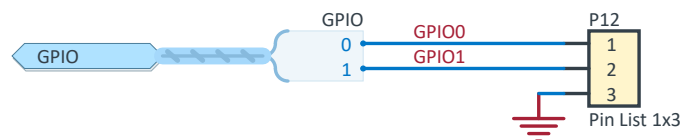

Figure 10: GPIO schematic

Pin	Pin name	Function
1	<b>GPIO0</b>	PMIC GPIO0
2	<b>GPIO1</b>	PMIC GPIO1
3	<b>GND</b>	Ground

Table 4: GPIO header signal description

**Note:** The PMIC GPIOs have the same voltage level as VOUT.

### 3.4.2 TWI

The I<sup>2</sup>C compatible TWI is used by the host device to control and monitor the nPM2100 PMIC.

The TWI pins are directly accessible on pin header **P11**.

The following figure and table show the schematic and function descriptions for the TWI.

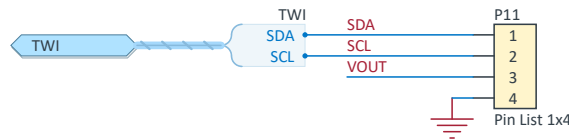

Figure 11: TWI schematic

Pin	Pin name	Function
1	<b>SDA</b>	TWI data line
2	<b>SCL</b>	TWI clock signal
3	<b>VOUT</b>	Boost regulator output
4	<b>GND</b>	Ground

Table 5: TWI header signal description

**Note:** The PMIC TWI has the same voltage level as VOUT.

### 3.4.3 SHPHLD

The **SHPHLD** input pin is available on pin header **P13** which is labeled **CONFIG**. The pin connects to the **SW2** button, which is normally open and used to enter or exit Ship mode.



Figure 12: SHPHLD schematic

### 3.4.4 PG/RESET

The **PG/RESET** input pin is available on pin header **P13** which is labeled **CONFIG**. The pin connects to the **SW1** button, which is normally open and used to reset nPM2100 or serve as an input.



Figure 13: PG/RESET schematic

## 3.5 Jumpers and switches

The nPM2100 EK has jumpers and switches for easy configuration and control options.

The following figure shows the default jumper configuration on the EK.

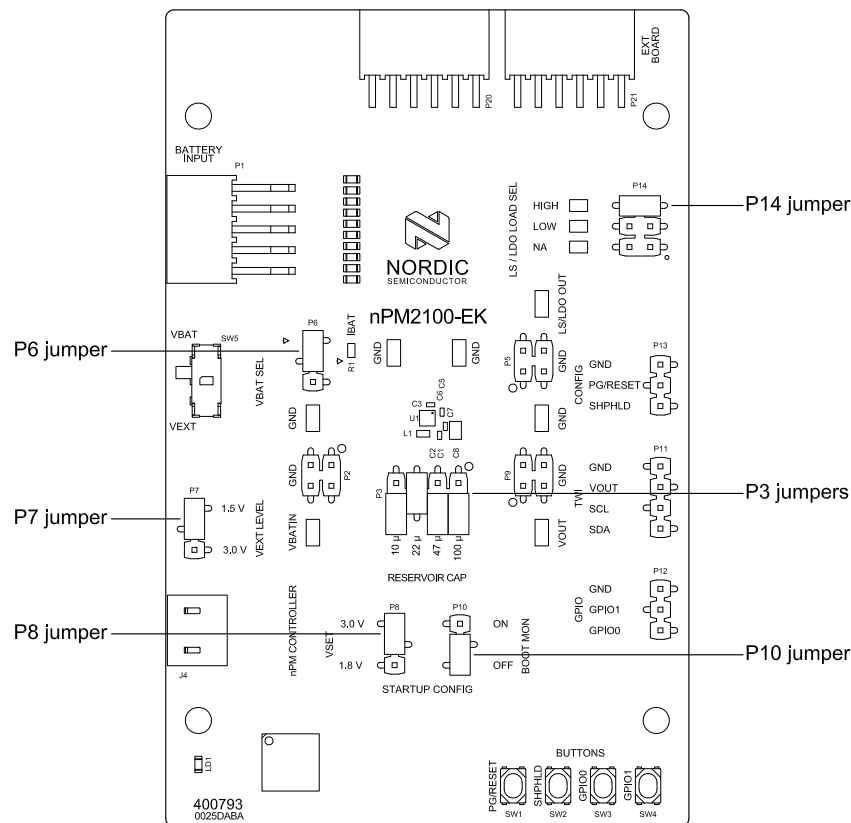

Figure 14: nPM2100 EK default jumper configuration

### 3.5.1 VBAT slide switch

Use the slide switch **SW5** which is labeled **VBAT SEL** to select the power supply for the nPM2100 PMIC.

Sliding **SW5** towards **VBAT** connects the battery source from the battery side (**VBAT**) to **VBATIN** on the PMIC side. Sliding **SW5** towards **VEXT** allows the onboard USB-powered LDO to power the PMIC.

For more information on alternative power sources, see [Use the nPM2100 EK with an alternative power source](#) on page 27.

The following figure shows the VBAT slide switch schematic.

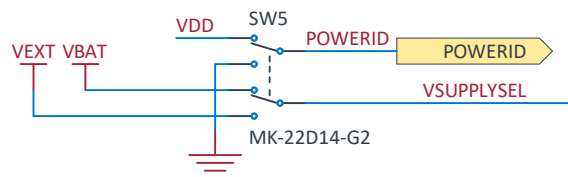

Figure 15: VBAT slide switch

### 3.5.2 BOOST startup configuration

The nPM2100 PMIC checks the status of the **VSET** pin at startup. Use a jumper on **P8** which is labeled **VSET** to set the output voltage to either 1.8 V or 3.0 V.

The output voltage is software configurable in 50 mV steps from 1.8 V to 3.3 V.

The following figure and table show the schematic and function descriptions for VSET.

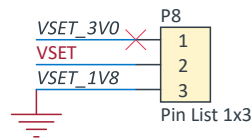

Figure 16: VSET schematic drawing

Configuration	Pin header	Connecting jumper pins		Output voltage (VOUT)
Output voltage	P8	VSET	3.0 V	3.0 V
			1.8 V	1.8 V

Table 6: VSET configuration

### 3.5.3 Load resistor selection

The load switch/LDO is powered from the boost regulator and used to configure the onboard current load connected to the nPM2100 **LSOUT/VOUTLDO** pin. Use a jumper on **P14** which is labeled **LS/LDO LOAD SEL** to select the load.

The following figure shows the loads on the LSOUT/VOUTLDO pin.

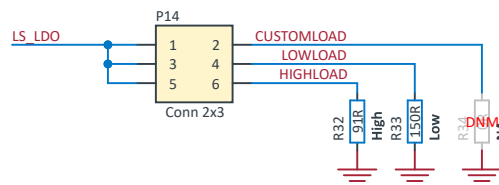

Figure 17: Load switch and LDO schematic

The following table shows options for selecting the load.

Configuration	PMIC pin	Connected load	Connecting jumper pins	Comment
Load switch or LDO output	LSOUT/ VOUTLDO	R32	P14 pin 5 to pin 6	High-current load, 91R
		R33	P14 pin 3 to pin 4	Low-current load, 150R
		R34	P14 pin 1 to pin 2	Customer specified load

Table 7: Load resistor configurations for load switch and LDO

### 3.5.4 Reservoir capacitors

Select the size of the VINT reservoir capacitor by placing one or more jumpers on **P3** which is labeled **RESERVOIR CAP**. You can configure various capacitor sizes by combining jumpers in different configurations.

The following figure shows the schematic for the reservoir capacitors.

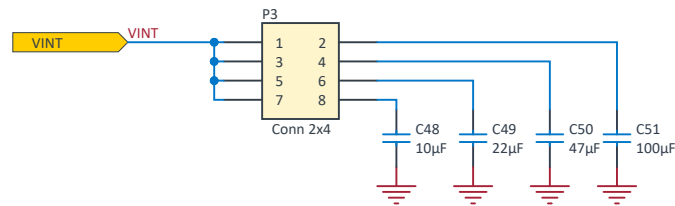

Figure 18: Reservoir capacitors

The following table shows options for configuring the reservoir capacitor.

Configuration	PMIC pin	Connected capacitor	Connecting jumper pins	Comment
Reservoir capacitance	<b>VINT</b>	C48	<b>P3</b> pin 7 to pin 8	10 $\mu$ F
		C49	<b>P3</b> pin 5 to pin 6	22 $\mu$ F
		C50	<b>P3</b> pin 3 to pin 6	47 $\mu$ F
		C51	<b>P3</b> pin 1 to pin 2	100 $\mu$ F

Table 8: Alternative reservoir capacitor configurations

**Note:** A 10  $\mu$ F capacitor on **C4** is permanently connected to VINT to provide minimal VINT capacitance.

**Note:** Disconnect the power source before reconfiguring the reservoir capacitor.

For more information on reservoir capacitor selection, see [nPM2100 Hardware Design Guidelines](#).

### 3.5.5 VEXT jumper

Use a jumper on **P7** which is labeled **VEXT LEVEL** to select the LDO output voltage level.

Configuration	Pin header	Connecting jumper pins		LDO output voltage (VEXT)
LDO output voltage	<b>P7</b>	<b>VEXT</b>	1.5 V	1.5 V
			3.0 V	3.0 V

Table 9: VEXT configuration

### 3.5.6 Boot monitor

The nPM2100 PMIC checks the status of the **SYSGDEN** pin at startup. Use a jumper on **P10** which is labeled **BOOT MON** to enable or disable boot monitoring.

Configuration	Pin header	Connecting jumper pins		Boot monitor
Boot monitoring	<b>P10</b>	<b>BOOT MON</b>	ON	ON
			OFF	OFF

Table 10: Boot monitor configuration

## 3.6 Buttons

The nPM2100 EK has four push buttons that short the following connected *PMIC* pins to ground.

The following table shows the button configuration on the EK.

Part	Parameter controlled (PMIC)	Function
SW1	PG/RESET	Reset nPM2100
SW2	SHPHLD	Enter and wake up from Ship mode
SW3	GPIO0	PMIC GPIO0
SW4	GPIO1	PMIC GPIO1

Table 11: Button configuration

## 3.7 Battery capacity indicator

When evaluating the nPM2100 EK using the nPM PowerUP app, the EK's battery capacity indicator displays the current battery level.

There are eight green diodes, one yellow diode, and one red diode, each representing 10% of the connected battery's capacity. When the battery is at 100%, all LEDs light up. If only the red LED is on, the battery capacity is between 0% and 10%.

The LED intensity for each diode has a step size of 1%. For example, if the battery capacity is at 38%, the first three LEDs— red, yellow, and green—light up with 100% intensity, while the fourth green LED lights up at 80% intensity.

For more information on battery capacity evaluations, see [Using the nPM2100 Fuel Gauge](#).

## 3.8 nPM Controller

The nPM Controller circuit on the nPM2100 EK enables easy interaction with the *PMIC* through the nPM PowerUP app or a terminal.

To enable software control, connect **nPM CONTROLLER** on **J4** to a computer using a compatible USB-C cable. To connect the EK and start using the nPM PowerUP, see [Connect and use the nPM2100 EK](#).

A green LED (**LD1**) next to the nPM Controller circuit shows the status of the nPM Controller and connection with the *PMIC*. The following table shows the LED light patterns and EK status.

LED	LED status	EK status	Actions
LD1 (green)	Fading on and off	Successful connection with nPM Controller	Correctly powered nPM Controller. No action needed.
	Blinking rapidly	No connection with nPM2100 PMIC	Incorrectly powered. Check if the PMIC has power or power cycle nPM Controller by unplugging and then reconnecting the USB cable.
	Off	nPM Controller not powered	Check if the EK is correctly powered through <b>J4</b> .

Table 12: LED pattern and EK status

# 4 Connect and use the nPM2100 EK

The nPM2100 EK provides three distinct development levels that range from simple evaluation to complete implementation.

The following development alternatives are available:

- Evaluating the nPM2100 *PMIC* without writing code or performing any device programming
- Using the EK with a Nordic *DK* to evaluate the *PMIC* or develop your own nPM2100 application
- Using the EK with your own custom hardware to evaluate the *PMIC* or develop your own *System on Chip (SoC)* application

## 4.1 Use the nPM2100 EK with nPM PowerUP

The nPM2100 EK provides connections for easy configuration and evaluation of the nPM2100 *PMIC* through the nPM PowerUP computer app.

Perform the following steps to set up the EK and start using the nPM PowerUP app.

1. Insert a battery in the battery add-on board ensuring the correct polarity as shown on the board.
2. Plug the battery add-on board in the nPM2100 EK socket labeled **BATTERY INPUT**.
3. Slide switch **SW5** to VBAT.
4. Use a USB-C cable to connect your computer to **nPM CONTROLLER** on **J4**.  
A green LED (**LD1**) indicates the status of the [nPM Controller](#) and nPM2100.
5. Download and install [nRF Connect for Desktop](#).
6. Open **nRF Connect for Desktop** and install the nPM PowerUP app.
7. Open **nPM PowerUP**.
8. Click **Select Device** on the left-side panel.
9. Select the **nPM2100 Evaluation Kit**.
10. Set the termination voltage and current limit in the **Charger** panel on the **DASHBOARD**.

You can now evaluate the EK, see the status of your battery, and use the built-in battery models in nPM PowerUP.

## 4.2 Use the nPM2100 EK with the nRF54L15 DK

The nPM2100 EK can power the nRF54L15 SoC as a host device on the nRF54L15 *DK*.

**Note:** The EK powers only the nRF54L15 SoC on the DK. The nRF54L15 DK must be powered externally to access the nRF54L15 DK features such as programming and debugging.

1. Connect the nPM2100 EK to the nRF54L15 DK as shown in [Figure 19: Connecting nPM2100 EK and nRF54L15 DK](#) on page 24.
2. To program and debug nRF54L15 SoC, connect a USB cable to the USB port **J3** on the DK.  
This powers only the IMCU used for programming and debugging.
3. On the EK, disconnect the USB-C cable from **J4** to put the EK in standalone mode.  
This disables the nPM Controller.
4. Insert a battery in the battery add-on board, ensuring correct polarity.

5. To power the EK, plug the battery add-on board in the EK socket labelled **BATTERY INPUT**.
6. Slide switch **SW5** to **VBAT**.

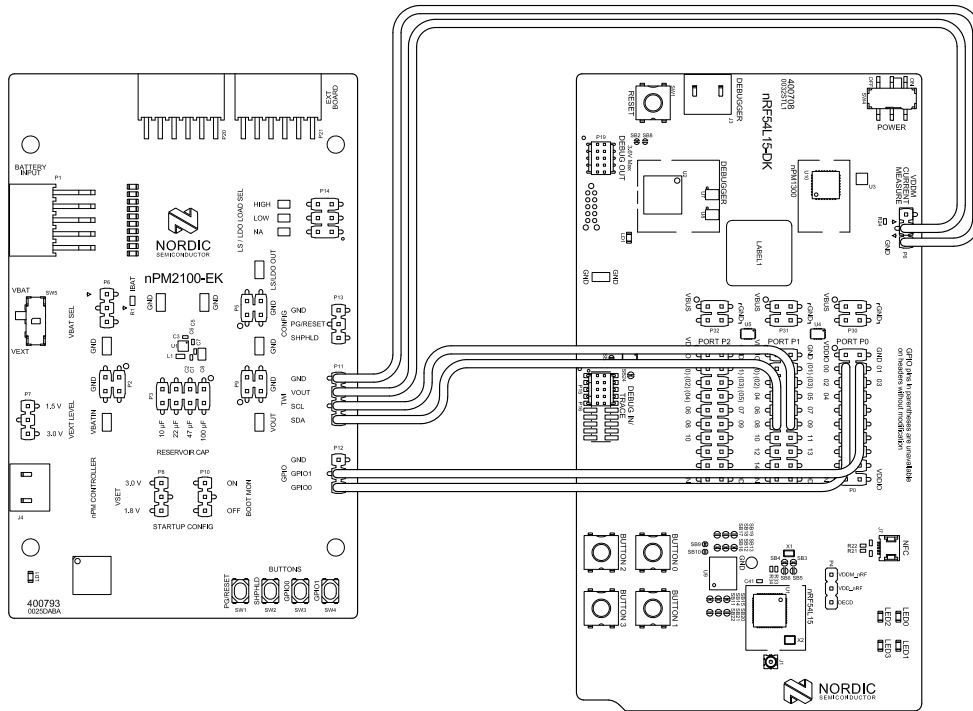

Figure 19: Connecting nPM2100 EK and nRF54L15 DK

**Note:** The nRF54L15 host device and the nPM2100 PMIC have the same I/O reference level.

The following table shows the connections between the EK and the nRF54L15 DK.

Function	nPM2100 EK		nRF54L15 DK		Comment
	Pin name	Location	Pin name	Location	
Power	VOUT	P11, pin 3	VDD	P6, pin 2	The nRF54L15 DK voltage can be adjusted in the <a href="#">Board Configurator app</a> application to match the nPM2100 VSET voltage
	GND	P11, pin 4	GND	P6, pin 1	Ground
TWI	SCL	P11, pin 2	P1 . 11	P1, pin 11	Connect to a TWI compliant GPIO on DK
	SDA	P11, pin 1	P1 . 12	P1, pin 12	Connect to a TWI compliant GPIO on DK
GPIO	GPIO0	P12, pin 1	P0 . 02	P0, pin 2	Connect to a GPIO on DK
	GPIO1	P12, pin 2	P0 . 04	P0, pin 4	Connect to a GPIO on DK

Table 13: Connections between nPM2100 EK and nRF54L15 DK

## 4.3 Use the nPM2100 EK with the nRF5340 DK

The nPM2100 EK can power the nRF5340 SoC as a host device on the nRF5340 DK.

**Note:** The EK powers only the nRF5340 SoC on the DK. To access the nRF5340 DK features, such as programming and debugging, the IMCU on the DK must be externally powered.

1. Connect the nPM2100 EK to the nRF5340 DK as shown in [Figure 20: Connecting nPM2100 EK and nRF5340 DK](#) on page 25.
2. On the DK, make sure the **VEXT→nRF** switch **SW10** is in the **ON** position.  
This connects the external supply to VDD. In this case, this connects the external supply to **VOUT** on the **PMIC**.
3. On the DK, make sure the **nRF POWER SOURCE** switch **SW9** is in the **VDD** position.  
This ensures that only the nRF5340 circuitry is powered from VDD.
4. To program and debug nRF5340 SoC, connect a USB cable to the USB port **J2** on the DK.  
This only powers the IMCU used for flashing and debugging.
5. On the EK, disconnect the USB-C cable from **J4** to put the EK in standalone mode.  
This disables the nPM Controller.
6. Insert a battery in the battery add-on board, ensuring correct polarity.
7. To power the EK, plug the battery add-on board in the EK socket at **P4**.
8. Slide switch **SW5** to **VBAT**.

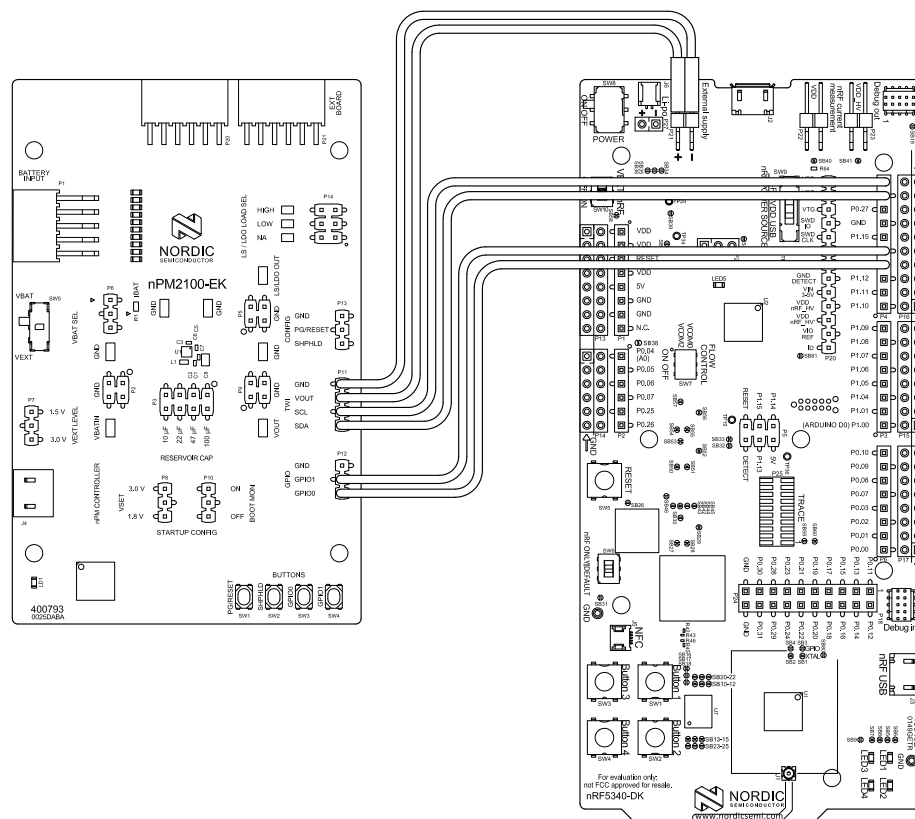

Figure 20: Connecting nPM2100 EK and nRF5340 DK

**Note:** The nRF5340 host device and the nPM2100 PMIC have the same I/O reference level.

The following table shows the connections between the EK and the nRF5340 DK.

Function	nPM2100 EK		nRF5340 DK		Comment
	Pin name	Location	Pin name	Location	
Power	<b>VOUT</b>	<b>P11</b> , pin 3	<b>External supply +</b> (positive)	<b>P21</b> , pin 1	3.0 V, change jumper on <b>VSET</b> to <b>3.0 V</b>
	<b>GND</b>	<b>P11</b> , pin 4	<b>External supply -</b> (negative)	<b>P21</b> , pin 2	Ground
TWI	<b>SCL</b>	<b>P11</b> , pin 2	<b>P1 . 02</b>	<b>P4</b> , pin 9	Connect to a TWI compliant GPIO on DK
	<b>SDA</b>	<b>P11</b> , pin 1	<b>P1 . 03</b>	<b>P4</b> , pin 10	Connect to a TWI compliant GPIO on DK
GPIO	<b>GPIO0</b>	<b>P12</b> , pin 1	<b>P1 . 10</b>	<b>P4</b> , pin 1	Connect to a GPIO on DK
	<b>GPIO1</b>	<b>P12</b> , pin 2	<b>P1 . 11</b>	<b>P4</b> , pin 2	Connect to a GPIO on DK

Table 14: Connections between nPM2100 EK and nRF5340 DK

## 4.4 Use the nPM2100 EK with the nRF52840 DK

The nPM2100 EK can power the nRF52840 SoC as a host device on the nRF52840 DK.

**Note:** The EK powers only the nRF52840 SoC on the DK. To access the nRF52840 DK features, such as programming and debugging, the IMCU on the DK must be externally powered.

1. Connect the nPM2100 EK to the nRF52840 DK as shown in [Table 15: Connections between nPM2100 EK and nRF52840 DK](#) on page 27.
2. On the DK, make sure the **VEXT→nRF** switch **SW10** is in the **ON** position.  
This connects the external supply to VDD. In this case, this connects the external supply to **VOUT** on the **PMIC**.
3. On the DK, make sure the **nRF POWER SOURCE** switch **SW9** is in the **VDD** position.  
This ensures that only the nRF52840 circuitry is powered from VDD.
4. To program and debug nRF52840 SoC, connect a USB cable to the USB port **J2** on the DK.  
This only powers the IMCU used for flashing and debugging.
5. On the EK, disconnect the USB-C cable from **J4** to put the EK in standalone mode.  
This disables the nPM Controller.
6. Insert a battery in the battery add-on board, ensuring correct polarity.
7. To power the EK, plug the battery add-on board in the EK socket at **P4**.
8. Slide switch **SW5** to **VBAT**.

**Note:** The nRF52840 host device and the nPM2100 PMIC have the same I/O reference level.

The following table shows the connections between the EK and the nRF52840 DK.

Function	nPM2100 EK		nRF52840 DK		Comment
	Pin name	Location	Pin name	Location	
Power	<b>VOUT</b>	<b>P11</b> , pin 3	<b>External supply +</b> (positive)	<b>P21</b> , pin 1	1.8 V, change jumper on <b>VSET</b> to <b>1.8 V</b>
	<b>GND</b>	<b>P11</b> , pin 4	<b>External supply -</b> (negative)	<b>P21</b> , pin 2	Ground
TWI	<b>SCL</b>	<b>P11</b> , pin 2	<b>P1 . 26</b>	<b>P4</b> , pin 9	Connect to a TWI compliant GPIO on DK
	<b>SDA</b>	<b>P11</b> , pin 1	<b>P1 . 27</b>	<b>P4</b> , pin 10	Connect to a TWI compliant GPIO on DK
GPIO	<b>GPIO0</b>	<b>P12</b> , pin 1	<b>P1 . 10</b>	<b>P4</b> , pin 1	Connect to a GPIO on DK
	<b>GPIO1</b>	<b>P12</b> , pin 2	<b>P1 . 11</b>	<b>P4</b> , pin 2	Connect to a GPIO on DK

Table 15: Connections between nPM2100 EK and nRF52840 DK

## 4.5 Use the nPM2100 EK with custom hardware

When the nPM2100 EK is used with custom hardware, make sure they are compatible in terms of voltage and current specifications.

The configuration process is similar to the nRF5340 DK, though some board-specific steps might differ.

**Note:** Ensure that the host device on the custom hardware and the nPM2100 PMIC have the same I/O reference levels as **VOUT**.

## 4.6 Use the nPM2100 EK with an alternative power source

The nPM2100 EK can be used with an external power supply or a battery simulator.

Perform the following steps to connect and use an alternative power source:

1. Remove the connected jumper on **P6** to disconnect the PMIC from VBAT or VEXT.
2. Select the required output voltage using a jumper on **P8**.
3. Connect the power source on pin header **P2** as follows:
  - a) Connect VBATIN to **P2** pin 1 and 2.
  - b) Connect GND to **P2** pin 3 and 4.

**Note:** The applied voltage must be between 0.7 V and 3.4 V.

4. Turn on the alternative power source.

# 5 Current measurements

The nPM2100 EK can be set up to monitor current flowing into the nPM2100 PMIC, from the battery, and into the external application.

Current can be measured using any of the following test instruments.

- [Power Profiler Kit II \(PPK2\)](#)
- Oscilloscope
- Ampere meter
- Power analyzer
- SMU

For higher precision results, using an SMU is recommended. The PPK2 is an affordable alternative to an SMU because it captures traces of both voltage and current changes.

The main power supply for the nPM2100 PMIC is **VBAT**. The complementary power supply is **VEXT**. The PMIC regulated output is **VOU<sub>T</sub>**.

Component	VBAT	VEXT	VOU <sub>T</sub>
Measurement connector	P6, pin 2 and pin 3	P6, pin 2 and pin 3	P9, pin 1 or pin 2 or VOU <sub>T</sub> probe loop
Series resistor	R1 (IBAT)	R1 (IBAT)	External
Series resistor range	≤1 Ω	≤1 Ω	≤1 Ω

Table 16: Components for current measurement

**Note:** If resistor **R1** is still mounted after measuring current and an external power source is connected, do not add a jumper to **P6**. This would connect VBAT or VEXT to the external power source output and potentially damage the EK or the power source.

The nPM2100 EK has a default jumper configuration described in [Jumpers and switches](#) on page 17. To ensure that the EK operates correctly without modifications, verify the jumper settings before powering up the EK. Before conducting measurements, connect the EK to a DC power source (VBUS) as described in the [Power supply](#) on page 12.

For more information on current measurement, see the tutorial [Current measurement guide: Introduction](#).

## 5.1 Measure current profile with an oscilloscope

An oscilloscope can be used to measure the average current over a given time interval and capture the current profile. Set up the EK according to the supply or output that you want to measure.

### Set up EK to measure VBAT and VEXT

1. Remove the jumper on **P6**.
2. Mount an **IBAT** current-measurement resistor on the footprint for **R1**. The recommended value is 1 Ω or lower.
3. Slide **SW5** to **VBAT** for battery measurements or **VEXT** for the onboard USB-powered LDO.

4. Use **P6** pin 2 and pin 3 as probe points for performing current measurements.

To restore the EK to default jumper settings after measurements, demount the **IBAT** series resistor and connect the jumper across pin 2 and pin 3 on **P6**.

### Set up EK to measure VOUT

1. Connect a suitable current-measurement resistor between the load and **VOUT** pin 1 or pin 2 on **P9** or loop clip. The recommended value is 1  $\Omega$  or lower.
2. Connect **GND** pin 3 or pin 4 on **P9** to the load ground to ensure proper system grounding.

**Note:** It is recommended to use standard jumper wires compatible with 2.54 mm (0.1") headers. Make sure the jumper wires are rated for the current.

## 5.1.1 Measure VBAT, VEXT, and VOUT using an oscilloscope

Make sure you have prepared the EK for the given measurement case, as described in [Set up EK to measure VBAT and VEXT](#) on page 28 or [Set up EK to measure VOUT](#) on page 29.

Perform the following steps to measure the current using an oscilloscope.

1. Set the oscilloscope to differential mode or a mode that is similar.
2. Connect the oscilloscope using two probes across the probe points of interest depending on the measurement case.

[Figure 21: Current measurement with an oscilloscope](#) on page 30 shows the **VBAT** current-measurement case with probe points across the **IBAT** resistor between pins 2 and 3 on **P6**.

3. Calculate or plot the instantaneous current from the voltage drop across the **IBAT** resistor by taking the difference of the voltages measured on the two probes.

The voltage drop is proportional to the current. For instance, a 100 m $\Omega$  resistor causes a 0.1 mV drop for each 1 mA drawn by the circuit being measured.

The plotted voltage drop can be used to calculate the current at a given point in time. The current can then be averaged or integrated to analyze current and energy consumption over a period.

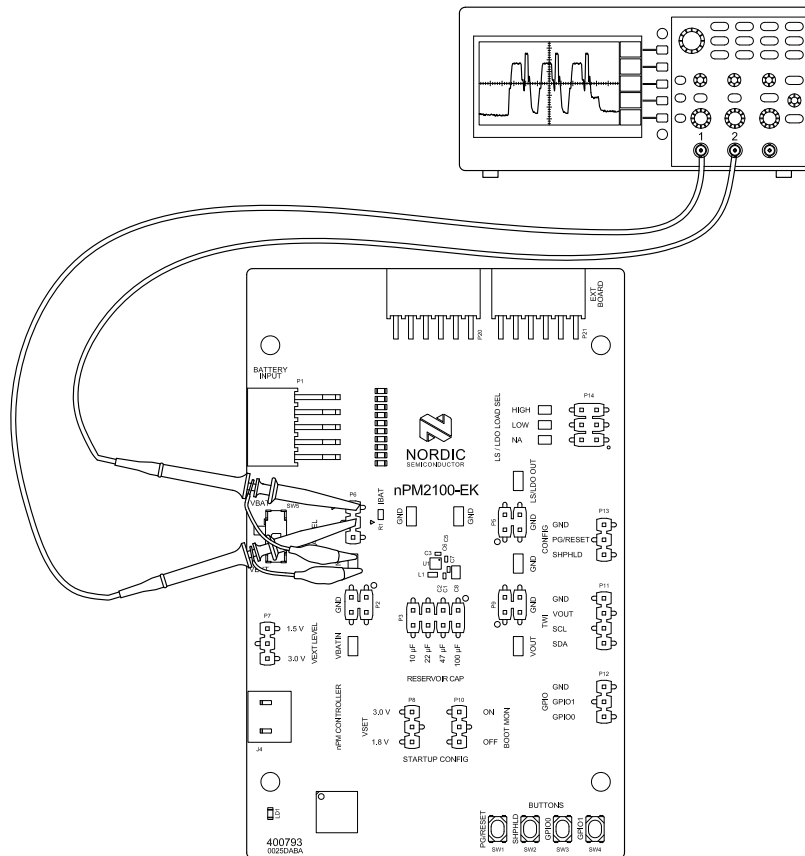

Figure 21: Current measurement with an oscilloscope

To reduce noise, do the following:

- Use probes with 1x attenuation.
- Enable averaging mode to reduce random noise.
- Enable high-resolution function if it is available.

Use a minimum of 200 kSa/s (one sample every 5  $\mu$ s) to get the correct average current measurement.

## 5.2 Measure average current with an ampere meter

Measure the current with an ampere meter by placing the ampere meter in series with the source or load and the probe point. Set up the *EK* according to the supply or output that you want to measure.

### Set up *EK* to measure VBAT and VEXT

1. Remove the jumper on **P6**.
2. Ensure there is no **IBAT** current-measurement resistor mounted on the footprint for **R1**.
3. Slide **SW5** to **VBAT** for battery measurements or **VEXT** for the onboard USB-powered LDO.
4. Use **P6** pin 2 and pin 3 as probe points for performing current measurements.

### Set up *EK* to measure VOUT

1. Connect the ampere meter between the load and **VOUT** pin 1 or pin 2 on **P9**.
2. Connect **GND** pin 3 or pin 4 on **P9** to the load ground to ensure proper system grounding.



PPK2 measurement mode	Parameters	Description
Ampere Meter	<b>VOUT</b>	Power outputs measured with the PPK2 in series between the output and the load
Source Meter (supply)	<b>IBAT</b>	Power inputs (supplies) measured with PPK2 as the power source into the EK

Table 17: Measurement modes for PPK2

For more information on the PPK2, see the [Power Profiler Kit II](#).

# Glossary

## **Application Programming Interface (API)**

A language and message format used by an application program to communicate with an operating system, application, or other service.

## **Development Kit (DK)**

A hardware development platform used for application development.

## **Electrostatic Discharge (ESD)**

A sudden discharge of electric current between two electrically charged objects.

## **Evaluation Kit (EK)**

A platform used to evaluate different development platforms.

## **Low-Dropout Regulator (LDO)**

A linear voltage regulator that can operate even when the supply voltage is very close to the desired output voltage.

## **Power Management Integrated Circuit (PMIC)**

A chip used for various functions related to power management.

## **Pulse Width Modulation (PWM)**

A form of modulation used to represent an analog signal with a binary signal where the switching frequency is fixed, and all the pulses corresponding to one sample are contiguous in the digital signal.

## **Software Development Kit (SDK)**

A set of tools used for developing applications for a specific device or operating system.

## **Source Measure Unit (SMU)**

An electronic instrument that is capable of both sourcing and measuring at the same time.

## **System on Chip (SoC)**

A microchip that integrates all the necessary electronic circuits and components of a computer or other electronic systems on a single integrated circuit.

# Recommended reading

In addition to the information in this document, you may need to consult other documents.

## **Nordic documentation**

- [nPM2100 Datasheet](#)
- [Using the nPM2100 Fuel Gauge](#)
- [nPM2100 EK product page](#)
- [nPM PowerUP app](#)

# Legal notices

By using this documentation you agree to our terms and conditions of use. Nordic Semiconductor may change these terms and conditions at any time without notice.

## Liability disclaimer

Nordic Semiconductor ASA reserves the right to make changes without further notice to the product to improve reliability, function, or design. Nordic Semiconductor ASA does not assume any liability arising out of the application or use of any product or circuits described herein.

Nordic Semiconductor ASA does not give any representations or warranties, expressed or implied, as to the accuracy or completeness of such information and shall have no liability for the consequences of use of such information. If there are any discrepancies, ambiguities or conflicts in Nordic Semiconductor's documentation, the Datasheet prevails.

Nordic Semiconductor ASA reserves the right to make corrections, enhancements, and other changes to this document without notice.

## Life support applications

Nordic Semiconductor products are not designed for use in life support appliances, devices, or systems where malfunction of these products can reasonably be expected to result in personal injury.

Nordic Semiconductor ASA customers using or selling these products for use in such applications do so at their own risk and agree to fully indemnify Nordic Semiconductor ASA for any damages resulting from such improper use or sale.

## RoHS and REACH statement

Complete hazardous substance reports, material composition reports and latest version of Nordic's REACH statement can be found on our website [www.nordicsemi.com](http://www.nordicsemi.com).

## Trademarks

All trademarks, service marks, trade names, product names, and logos appearing in this documentation are the property of their respective owners.

## Copyright notice

© 2026 Nordic Semiconductor ASA. All rights are reserved. Reproduction in whole or in part is prohibited without the prior written permission of the copyright holder.

