

nPM1300 EK Hardware

v1.1.0

User Guide

Contents

Revision history	iv
Environmental and safety notices	v
1 Introduction	7
2 Minimum requirements	9
3 Kit content	10
4 Hardware description	11
4.1 Block diagram	12
4.2 Power supply	13
4.3 Battery temperature monitoring	14
4.4 Output connections	14
4.5 I/O pins	15
4.5.1 LEDs	16
4.5.2 GPIOs	16
4.5.3 TWI	17
4.5.4 VSET	17
4.5.5 SHPHLD	18
4.5.6 VDDIO	18
4.5.7 Load switches/LDOs	19
4.6 Jumpers	19
4.6.1 VBAT jumper	20
4.6.2 NTC jumper	20
4.6.3 Buck startup configuration	21
4.6.4 VDDIO reference voltage	21
4.6.5 Load switch configuration	22
4.6.6 LDO bypass capacitors	22
4.6.7 LED jumper connections	23
4.7 Buttons	23
4.8 nPM Controller	24
4.9 nPM Fuel Gauge Board	24
5 Connect and use the nPM1300 EK	26
5.1 Evaluate nPM1300 using nPM PowerUP	26
5.1.1 Connect the nPM1300 EK with nPM PowerUP	26
5.1.2 Connect the nPM1300 EK with the nPM Fuel Gauge Board	27
5.2 Use the nPM1300 EK with an nRF5340 DK	28
5.3 Use the nPM1300 EK with custom hardware	30
6 Measure current	31
6.1 Use an oscilloscope for current measurements	32
6.1.1 Prepare for VBAT current measurements	32
6.1.2 Prepare for VBUS and VOUT current measurements	32
6.1.3 Measure VBAT, VBUS, and VOUT using an oscilloscope	32
6.2 Use an ampere meter for current measurements	33
6.2.1 Prepare for VBAT, VBUS, and VOUT current measurements	33

6.2.2 Measure VBAT, VBUS, and VOUT using an ampere meter.	34
6.3 Use a Power Profiler Kit II for current measurements.	35
6.3.1 Measure VBAT current.	35
6.3.2 Measure VBUS current.	36
6.3.3 Measure VOUT1 or VOUT2 current.	37
Glossary	39
Recommended reading.	41
Legal notices.	42

Revision history

Date	Description
April 2024	Updated: <ul style="list-style-type: none">• Minimum requirements on page 9 Editorial changes
March 2024	Updated: <ul style="list-style-type: none">• nPM Fuel Gauge Board on page 24• Connect the nPM1300 EK with the nPM Fuel Gauge Board on page 27 Editorial changes
November 2023	Added: <ul style="list-style-type: none">• Connect and use the nPM1300 EK on page 26• Evaluate nPM1300 using nPM PowerUP on page 26• Connect and use the nPM1300 EK on page 26• Connect the nPM1300 EK with the nPM Fuel Gauge Board on page 27 Updated: <ul style="list-style-type: none">• Removed known issues for EK v0.9.1 and 0.9.0 in:<ul style="list-style-type: none">• Introduction on page 7• Jumpers on page 19• Buttons on page 23• Minimum requirements on page 9• Schematic drawings:<ul style="list-style-type: none">• TWI on page 17• VDDIO reference voltage on page 21• nPM Fuel Gauge Board on page 24• Measure VBAT, VBUS, and VOUT using an oscilloscope on page 32 Editorial changes
October 2023	Updated: <ul style="list-style-type: none">• New known issues with nPM1300 v0.9.1• Updated figure for Connecting PPK2 to measure VBAT
June 2023	First release

Previous versions

PDF files for relevant previous versions are available here:

- [nPM1300 EK User Guide v0.9.1](#)
- [nPM1300 EK User Guide v0.9.0](#)

Environmental and safety notices

Environmental and safety notices for the nPM1300 EK and power supply requirements.

Skilled persons

The nPM1300 EK is intended for use only by skilled persons.

A skilled person is someone with relevant education or experience that enables them to identify potential hazards and takes appropriate action to reduce the risk of injury to themselves and others.



Electrostatic discharge

The nPM1300 EK is susceptible to *Electrostatic Discharge (ESD)*.

To avoid damage to your device, it should be used in an electrostatic free environment, such as a laboratory.



Battery replacement

Warning: Due to the following safety concerns the battery in this product shall only be removed or replaced by qualified professionals:

- Replacing the battery with an incorrect battery type can cause a fire or explosion.
- Disposing the battery into a fire or hot oven, crushing it mechanically, or cutting it can cause an explosion.
- Leaving the battery in an environment with an extremely high temperature can cause an explosion or the leakage of flammable liquid or gas.
- Subjecting the battery to extremely low air pressure can cause an explosion or the leakage of flammable liquid or gas.

Pay attention to the polarity of the battery connectors. Connecting the polarity the wrong way causes the device to become very hot.





Environmental Protection

Waste electrical products should not be disposed of with household waste.

Please recycle where facilities exist. Check with your local authority or retailer for recycling advice.



1 Introduction

The nPM1300 *Evaluation Kit (EK)* is a hardware platform used to evaluate the nPM1300 *Power Management Integrated Circuit (PMIC)*.

To profile batteries and generate a battery model used for accurate fuel gauging, use the nPM1300 EK with the nPM Fuel Gauge Board. For more information, see [nPM Fuel Gauge Board Hardware](#).

Key features

- Dedicated *Universal Serial Bus (USB)* Type-C connection to power the nPM1300 PMIC
- Battery connectors that support *Negative Temperature Coefficient (NTC)* thermistor connection for battery temperature monitoring
- Easy access to PMIC voltage outputs through male pin headers and probe loops
- No hardware changes needed for measuring key parameters
- Exposed jumper pins to:
 - Select VSET configuration (resistor, external, or off)
 - Connect to *General-Purpose Input/Output (GPIO)s*
 - Configure load switches or *Low-Dropout Regulator (LDO)s*
 - Connect LEDs
- Onboard nPM Controller circuit for PMIC configuration when connected to a computer
- Plug-and-play connection to nPM PowerUP, a computer app that enables quick evaluation and implementation of Nordic PMICs
- Evaluate without writing any code or performing any device programming, when used with nPM PowerUP
- Use with a Nordic *Development Kit (DK)*, or develop your own nPM1300 application
- Use with your own custom hardware, or develop your own nPM1300 application

nPM1300 PMIC

- 800 mA battery charger
- Two 200 mA buck regulators
- Two 100 mA load switches / 50 mA LDOs
- Two-button hard reset
- Fuel gauge
- System-level watchdog and failed-boot recovery
- Intelligent power-loss warning
- Five GPIOs
- Three LED drivers
- Controlled using *Inter-integrated Circuit (I²C)* compatible TWI
- USB-C compatible

nPM PowerUP

- Computer application to simplify evaluation and implementation of Nordic PMIC applications
- Ability to configure, evaluate, and export all nPM1300 features
- Intuitive user experience for a seamless HW-FW-SW solution
- Battery profiling to generate a battery model for fuel gauging using the plug-and-play [nPM Fuel Gauge Board](#)

- Available for download from [nRF Connect for Desktop](#)

2 Minimum requirements

Before you start, check that you have the required hardware and software.

Hardware requirements

- USB Type-C cable with 1.5 A current capability to power the *PMIC*
- USB Type-C cable with USB 2.0 High Speed compatibility to power the nPM Controller
- Wires (2.54 mm / 0.1" pitch) for connecting the *EK* with a Nordic *DK*, or your own device
- Batteries
- [nPM Fuel Gauge Board](#) to profile batteries and generate a battery model

The EK supports the following types of batteries:

- Lithium-ion (Li-ion)
- Lithium-polymer (Li-poly)
- Lithium iron phosphate (LiFePO₄)

Software requirements

- nPM PowerUP available from [nRF Connect for Desktop](#)

3 Kit content

The nPM1300 EK includes hardware and access to software components, hardware design files, and documentation.

The kit contains the nPM1300 Evaluation Board with pre-mounted jumpers.

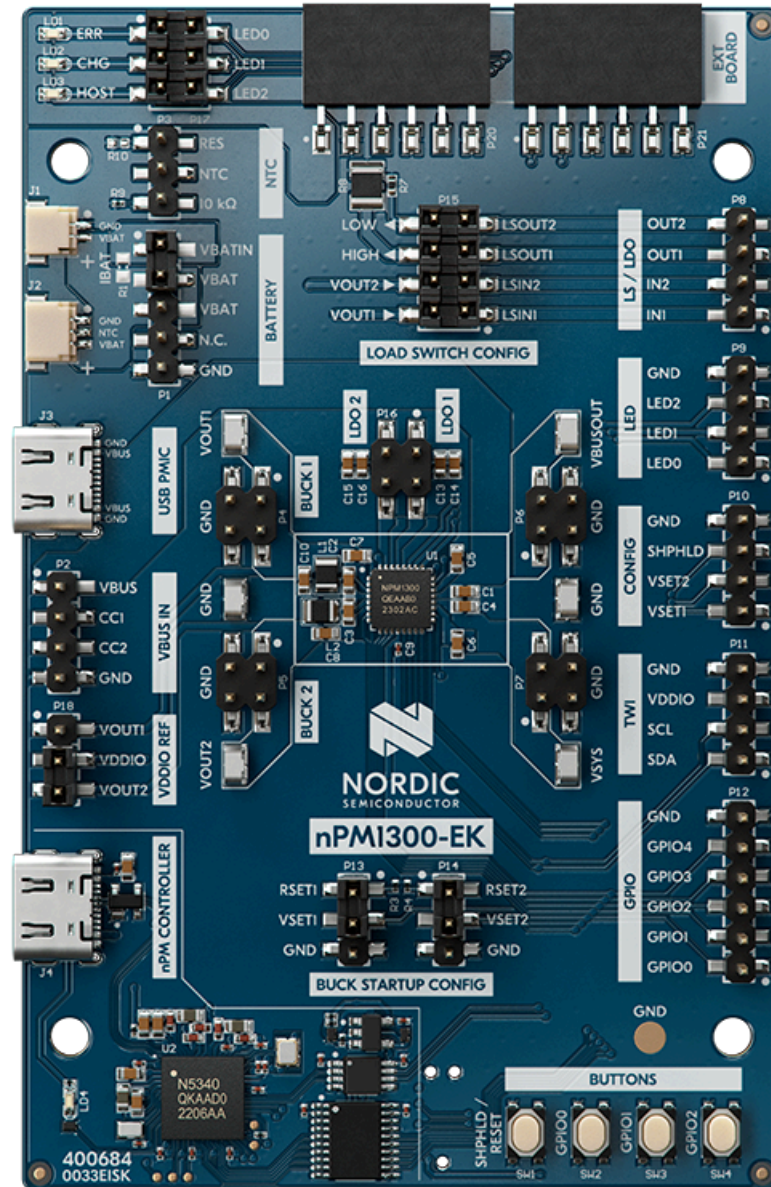

Figure 1: nPM1300 EK

Hardware files

The hardware design files including schematics, *Printed Circuit Board (PCB)* layout files, bill of materials, and Gerber files for the nPM1300 EK are available on the [nPM1300 EK product page](#).

4 Hardware description

The nPM1300 EK enables the evaluation of different functions and features of the nPM1300 PMIC without extra programming and allows for full configuration flexibility without having to make any hardware modifications.

Jumpers allow for quick configuration. You can use the jumpers to control the output state of the PMIC and operation mode of the BUCK regulators and disable parts of the EK. You can change the output voltages of the regulators and open the full potential of the PMIC using the provided library and sample code.

The following figures show the front and back of the nPM1300 EK.

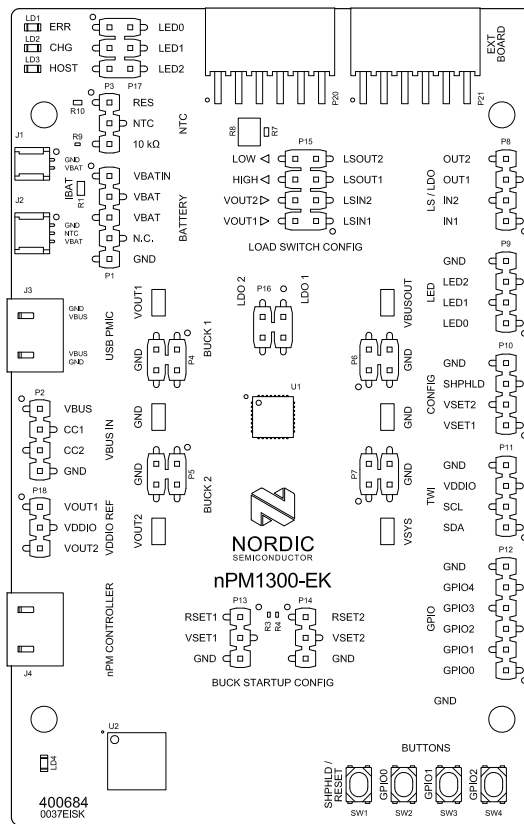

Figure 2: nPM1300 EK hardware drawing, front view

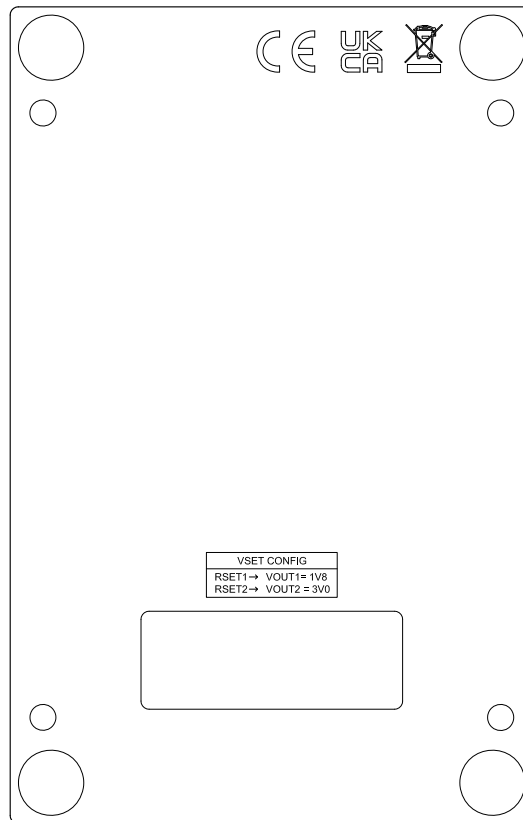

Figure 3: nPM1300 EK hardware drawing, back view

4.1 Block diagram

The block diagram illustrates the nPM1300 EK functional architecture.

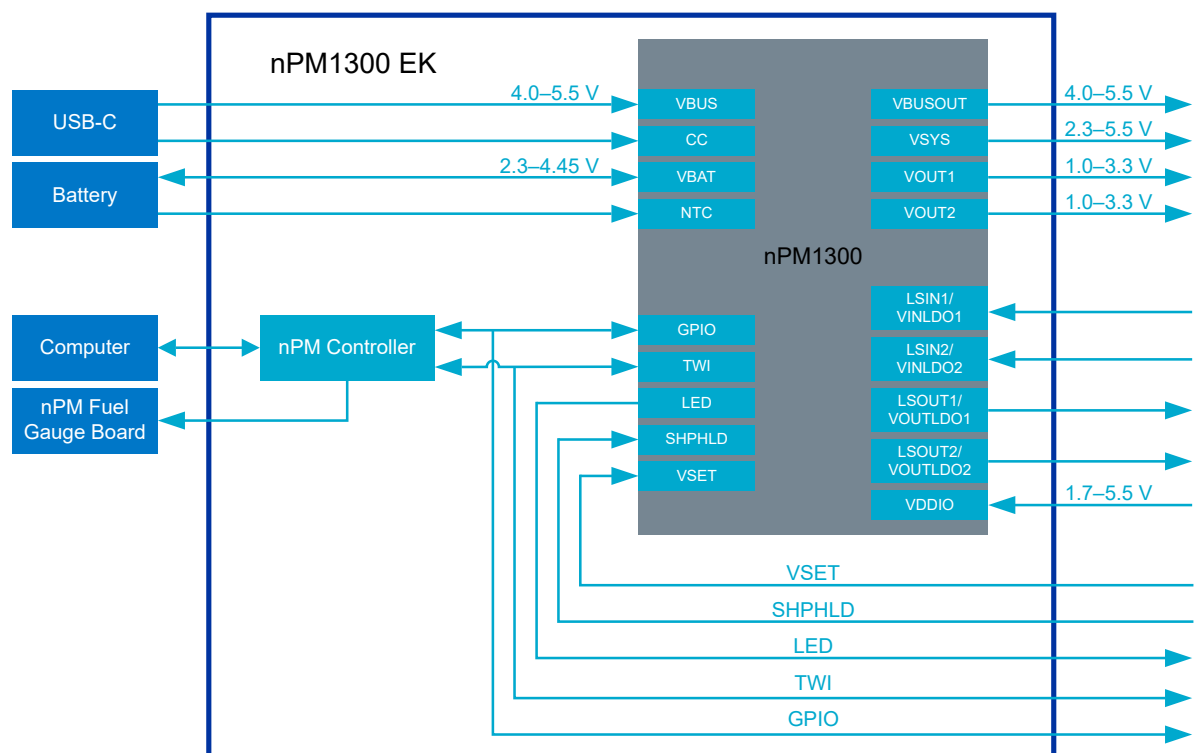

Figure 4: nPM1300 EK block diagram

4.2 Power supply

The nPM1300 *EK* has a flexible and configurable power supply system to allow testing with different power sources and to facilitate accurate power measurements.

The power supply to the nPM1300 *PMIC* is from *USB* (*VBUS*) or battery (*VBAT*). The input voltage ranges from 2.3 V to 5.5 V, depending on the source.

USB power is the main input source and the source for battery charging. A compatible battery connected to the *EK* acts as a complementary power source. The battery powers the *EK* if no external power source is connected to **USB PMIC** on **J3**, or **VBUS** on **P2**.

The *USB-C* connector, **nPM CONTROLLER** on **J4**, powers the nPM Controller and its circuitry when evaluating the *PMIC* in the nPM PowerUP computer app.

The following figure shows the power supply options for the nPM1300 *EK*.

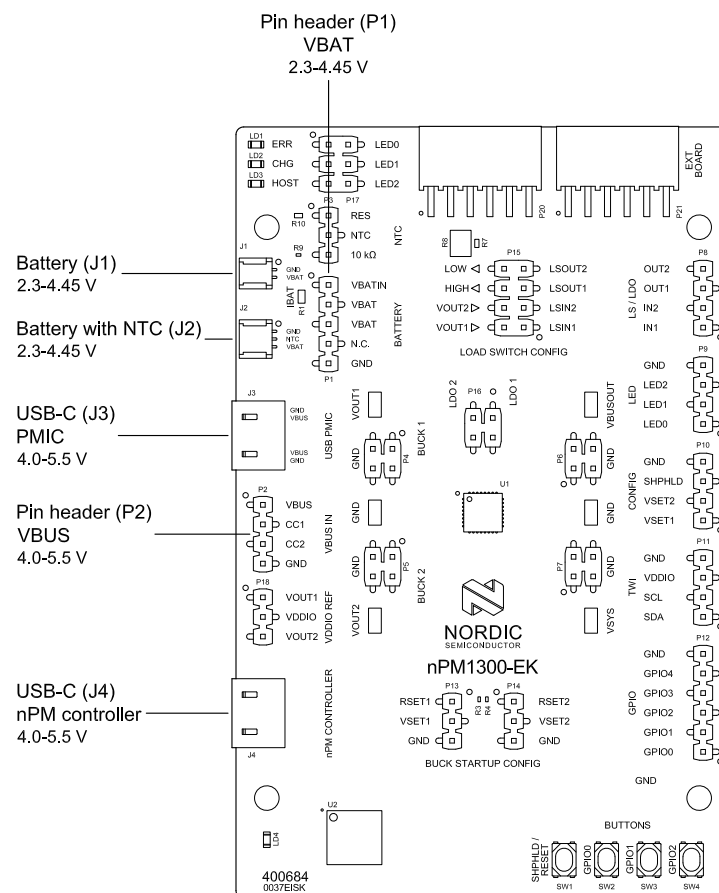

Figure 5: Power supply options

The following table shows the alternatives for connecting the main and complementary power input sources on the *EK*.

Input source		Part	Connector type	Comment
Main	VBUS	J3	USB-C	Only USB power on this connector
	4.0 V to 5.5 V	P2	Pin header	VBUS on pin 1
Complimentary	VBAT 2.3 V to 4.45 V	J1	JST SM02B header (2 pins)	Battery without <i>NTC</i> thermistor, ground on pin 1
		J2	JST SM03B header (3 pins)	Battery with <i>NTC</i> thermistor, ground on pin 1
		P1	Pin header	VBAT on pin 3

Table 1: Options for connecting power input sources

Note:

- To keep the operating temperature of the EK within safe limits the recommended input current on VBUS is 1 A.
- The maximum allowed input current on VBUS is determined by the power delivery negotiation between host and PMIC.
- Pay attention to the polarity of the battery connectors (**J1/J2**). Connecting the polarity the wrong way causes the device to become very hot. The nPM1300 EK uses JST configuration B, where pin 1 is **GND**.
- A battery without an *NTC* thermistor requires an external resistor to be terminated to **GND** on the **NTC** pin on pin header **P3**.



4.3 Battery temperature monitoring

The nPM1300 *PMIC* monitors battery temperature using *NTC* thermistors, available on different connectors on the *EK*.

When using a battery pack with an integrated *NTC* thermistor, use battery connector **J2**. Leave **NTC** pin on **P3** unconnected.

When using a battery pack without an integrated *NTC* thermistor on **J1** or header **P1**, use the integrated 10 k Ω resistor on the *EK* or a custom resistor. See [NTC jumper](#) on page 20 for more information.

If there is no *NTC* thermistor in the battery pack and a resistor is not connected between **NTC** and **GND** on **P3**, charging will not occur, and the charging LED (**CHG**) does not light up.

4.4 Output connections

The regulated outputs, **VOU1** and **VOU2**, and the unregulated outputs, **VBUSOUT** and **VSYS**, are accessible on the nPM1300 *EK* through pin headers and probe loops.

The connection options are:

- Pin headers—use to power other devices like the nRF5340 *DK*, nRF5340 Audio *DK*, or custom hardware.
- Probe loops—use to test the performance of the nPM1300 *PMIC* using lab equipment like electronic load, a *Source Measure Unit (SMU)*, oscilloscope, or the Power Profiler Kit II (PPK2).

In addition, the load switches or *LDO* outputs are available on pin headers. For more information, see [Load switches/LDOs](#) on page 19.

The following figure shows the pin headers and probe loops for the power outputs on the nPM1300 *EK*.

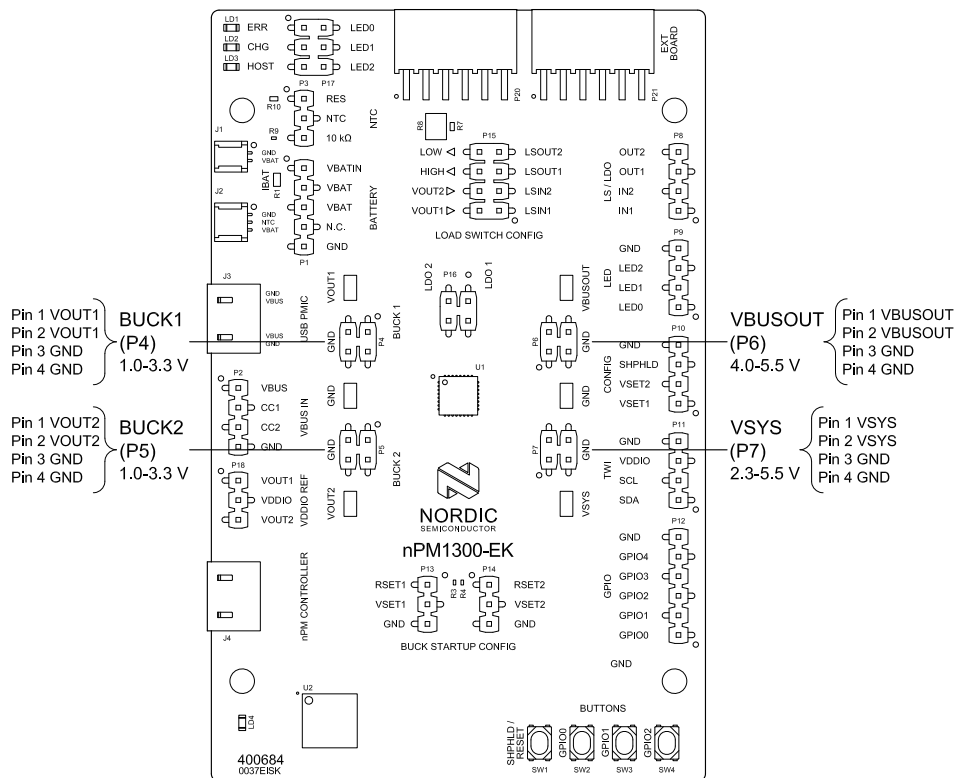

Figure 6: Pin headers and probe loops for power outputs

4.5 I/O pins

The nPM1300 *EK* provides connections to status and control pins of the nPM1300 *PMIC*, including five *GPIOs* available for custom workflows.

All status and control pins on the *PMIC* are accessible on pin headers. For default I/O pin configuration of the *EK* see [Jumpers](#) on page 19.

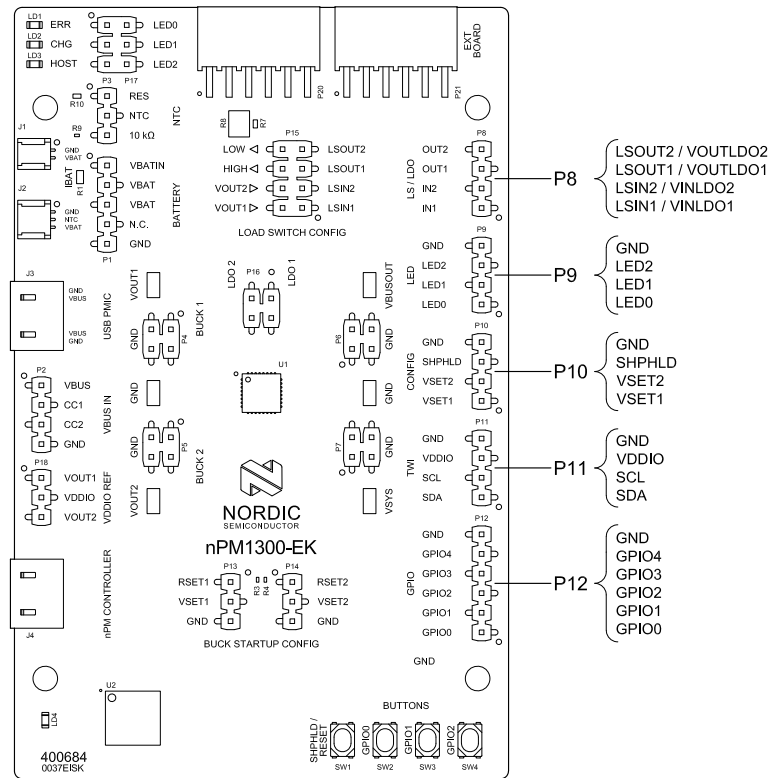

Figure 7: nPM1300 EK I/O pin headers

4.5.1 LEDs

The nPM1300 PMIC has three programmable LED pins, located on pin header **P9**.

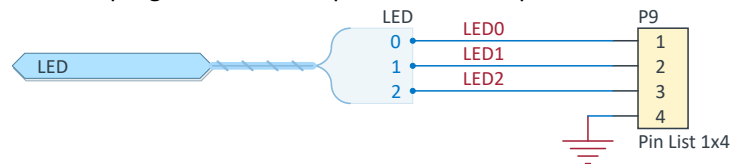

Figure 8: LED schematic

The LED pins can sink constant current up to 5 mA. In addition, the pins can be configured in software to be open-drain connections. The table shows the default settings of the LEDs.

Pin	Pin name	Default indication mode
1	LED0	ERR (error)
2	LED1	CHG (charging)
3	LED2	HOST (host activity)
4	GND	N/A (ground)

Table 2: Default function of LED pins

4.5.2 GPIOs

Five *GPIOs* are available on pin header **P12**. The *GPIOs* can be configured using the nPM Controller, or an external host.

All *GPIOs* are inputs with weak pull-down by default.

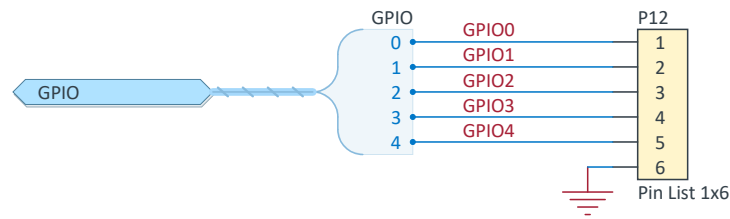

Figure 9: GPIO schematic

Pin	Pin name	Function
1	GPIO0	PMIC GPIO0
2	GPIO1	PMIC GPIO1
3	GPIO2	PMIC GPIO2
4	GPIO3	PMIC GPIO3
5	GPIO4	PMIC GPIO4
6	GND	Ground

Table 3: GPIO pin functionality

4.5.3 TWI

The I2C compatible TWI is used by the host device to control and monitor the nPM1300 PMIC.

The TWI pins are directly accessible on pin header **P11**.

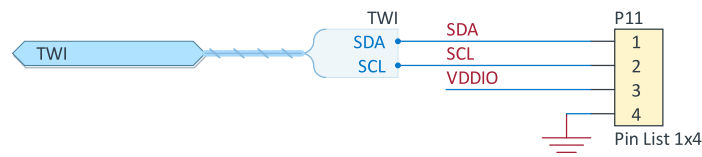

Figure 10: TWI schematic

Pin	Pin name	Function
1	SDA	TWI data line
2	SCL	TWI clock signal
3	VDDIO	TWI voltage reference
4	GND	Ground

Table 4: TWI pin functionality

4.5.4 VSET

The BUCK regulator configuration pins **VSET1** and **VSET2** are available on pin header **P10** (labeled **CONFIG**) for custom BUCK startup configuration through compatible resistors values.

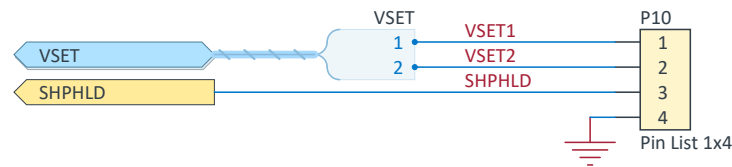

Figure 11: VSET schematic

The **VSET1** and **VSET2** pins are only effective at power up. The external resistor (maximum 5% tolerance) defines the default output voltage setting as found in the following table.

Resistor value	Output voltage	
	VOUT1	VOUT2
< 100 Ω (grounded)	0 V (OFF)	0 V (OFF)
4.7 k Ω	1.0 V	1.8 V
10 k Ω	1.2 V	2.0 V
22 k Ω	1.5 V	2.2 V
47 k Ω	1.8 V (RSET1)	2.4 V
68 k Ω	2.0 V	2.5 V
100 k Ω	2.2 V	2.7 V
150 k Ω	2.5 V	3.0 V (RSET2)
250 k Ω to 500 k Ω	2.7 V	3.3 V

Table 5: Output voltage of VOUT1 and VOUT2

Note: When using external VSET resistors remember to disconnect the default VSET jumpers on pin headers **P13** and **P14**.

4.5.5 SHPHLD

The **SHPHLD** input pin is available on pin header **P10** (labeled **CONFIG**).

Use **SHPHLD** pin to exit Ship mode and Hibernation mode. It can also be used to reset (and power cycle) nPM1300.

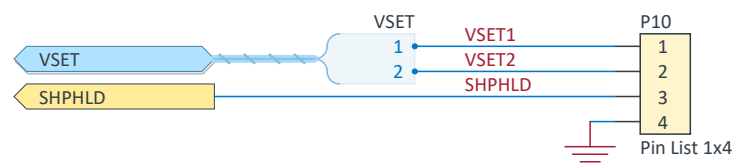

Figure 12: SHPHLD schematic

4.5.6 VDDIO

The **VDDIO** external reference voltage pin is available on pin header **P11** (labeled **TWI**). This is for external voltage input and sets the reference voltage level for the *GPIOs* and the *TWI*.

If using external **VDDIO** supply on **P11**, disconnect the VDDIO input jumper on **P18**. See further details in [VDDIO reference voltage](#) on page 21.

VDDIO is shown in [Figure 10: TWI schematic](#) on page 17.

Note: The minimum **VDDIO** voltage is 1.7 V. Any lower voltage can result in lost TWI communication between host and the nPM1300 PMIC.

4.5.7 Load switches/LDOs

The load switch pins are available on pin header **P8**. To configure the pins as *LDOs* add bypass capacitors by placing a jumper on pin header **P16**.

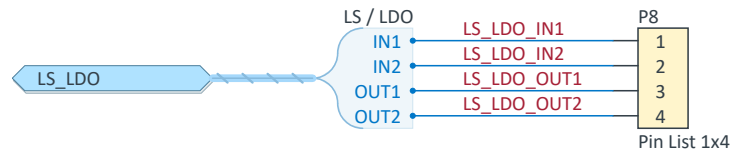

Figure 13: Load switches/LDO schematic

Pin	Pin name	Load switch	LDO
1	IN1	LSIN1	VINLDO1
2	IN2	LSIN2	VINLDO2
3	OUT1	LSOUT1	VOUPLDO1
4	OUT2	LSOUT2	VOUPLDO2

Table 6: Load switches and LDOs

For further information on LDOs, see [LDO bypass capacitors](#) on page 22.

4.6 Jumpers

The nPM1300 *EK* has jumpers for easy configuration and control options.

The following figure shows the default jumper configuration of the *EK*.

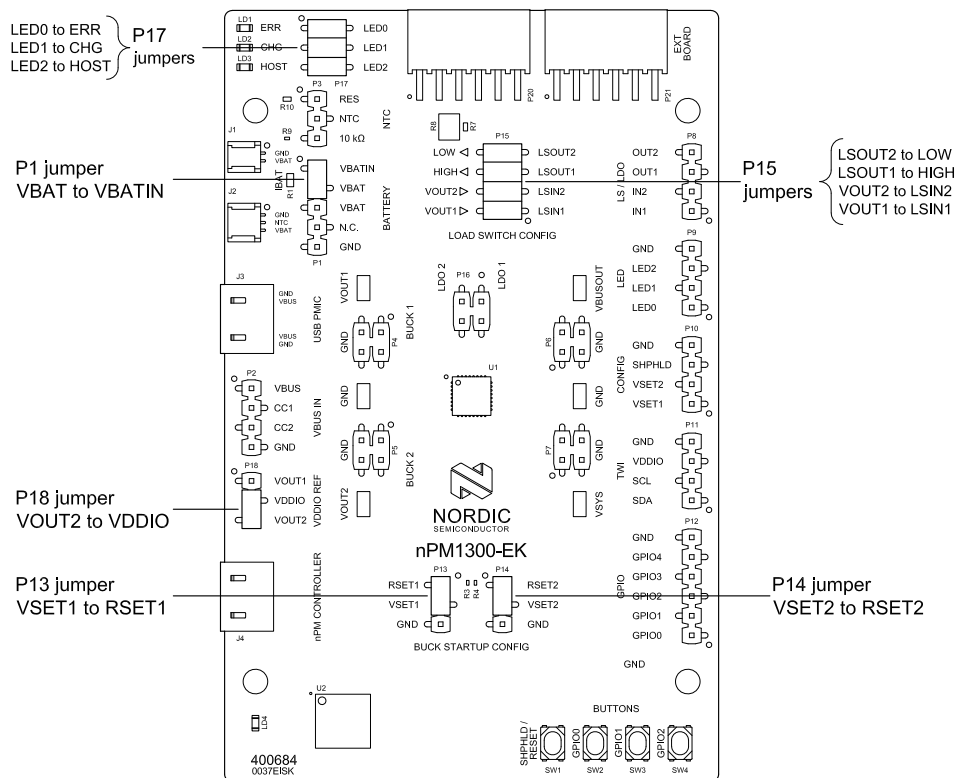

Figure 14: nPM1300 EK default jumper configuration

4.6.1 VBAT jumper

For the battery to be connected to the nPM1300 PMIC, a jumper must be connected between pin 1 and pin 2 on pin header **P1**. This connects **VBAT** to **VBATIN**.

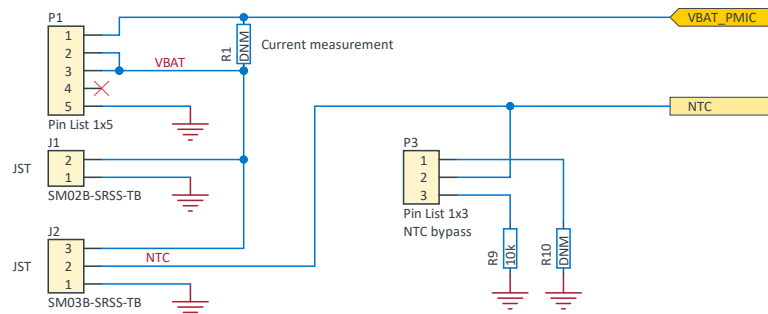

Figure 15: VBAT and NTC jumper schematic

Note: During current measurements with a resistor mounted on **R1**, make sure the **VBAT** jumper on **P1** is not connected. For more information, see [Measure current](#) on page 31.

4.6.2 NTC jumper

If using a battery without an **NTC** thermistor, connect a jumper between **NTC** (pin 2) and **10 kΩ** (pin 3) on pin header **P3** to use the integrated 10 kΩ resistor **R9**.

For a custom resistor there is an empty resistor footprint **R10** available on **P3** (pin 1). To use **R10** connect a jumper between **RES** (pin 1) and **NTC** (pin 2) on pin header **P3**.

The NTC schematic is shown in [Figure 15: VBAT and NTC jumper schematic](#) on page 20.

Pin	Pin name	Function
1	RES	Resistor R10 to GND (unmounted)
2	NTC	PMIC NTC input
3	10 kΩ	Resistor R9 to GND

Table 7: NTC jumper header

4.6.3 Buck startup configuration

The nPM1300 PMIC requires a startup VSET condition for the BUCK regulators.

Use jumpers on **P13** and **P14** to connect **VSET1** and **VSET2** to the fixed resistors **RSET1** and **RSET2**, or to **GND**.

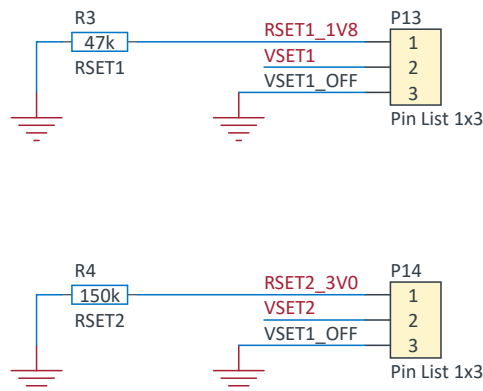

Figure 16: VSET schematic drawing

Configuration	Pin header	Jumper connection		Buck output voltage (VOUT)
BUCK1	P13	VSET1	RSET1	1.8 V
			GND	0 V (OFF)
BUCK2	P14	VSET2	RSET2	3.0 V
			GND	0 V (OFF)

Table 8: Buck startup configuration

An external VSET pulldown resistor can also be connected to **VSET1** and **VSET2** on pin header **P10**. In this case, disconnect the jumpers on **P13** and **P14**. Resistor values are given in [Table 5: Output voltage of VOUT1 and VOUT2](#) on page 18.

RSET1 is 47 k Ω and sets **BUCK1** to 1.8 V. **RSET2** is 100 k Ω and sets **BUCK2** to 3.0 V.

The VSET configuration is printed on the back side of the EK.

Note: To avoid issues with floating pins ensure that the VSET pins have the correct configuration.

4.6.4 VDDIO reference voltage

To set the reference voltage level for the *GPIOs* and the TWI, use a jumper to connect either **VOUT1** or **VOUT2** to **VDDIO** on **P18**.

When using the default jumper configuration on the EK, VDDIO is supplied locally by **VOUT2** on **P18**.

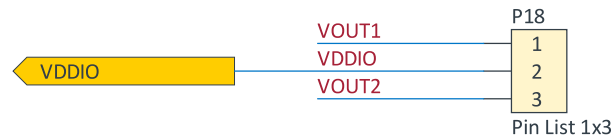

Figure 17: VDDIO schematic

Note: The minimum **VDDIO** voltage is 1.7 V. Any lower voltage can result in lost TWI communication between host and nPM1300 *PMIC*.

Note: If **VDDIO** is supplied externally, leave the jumper on **P18** unconnected.

See **VDDIO** on page 18 for more information on external supply.

4.6.5 Load switch configuration

The load switches can be connected to the BUCK regulators and two respective loads on the *EK*.

The load switch inputs are connected to **VOUT1** and **VOUT2** with jumpers on **P15**. The load switch outputs are connected to a low-current and a high-current load.

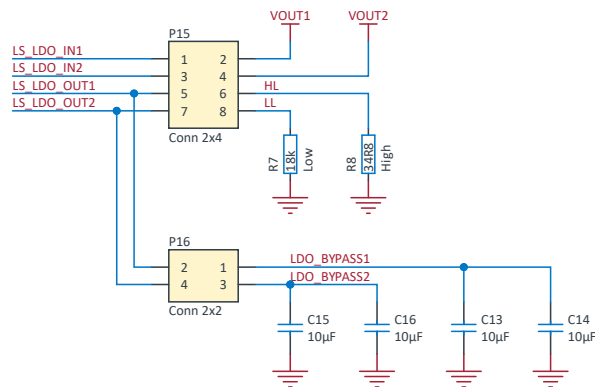

Figure 18: Load switch and LDO schematic

The following table show options for configuring the load switch inputs and outputs.

Configuration	PMIC pin	Connected net	Connecting jumper pins	Comment
Load switch input	LSIN1	VOUT1	P15 pin 1 to pin 2	Load switch source is BUCK1
	LSIN2	VOUT2	P15 pin 3 to pin 4	Load switch source is BUCK2
Load switch output	LSOUT1	R8	P15 pin 5 to pin 6	High-current load, 34.8 Ω
	LSOUT2	R7	P15 pin 7 to pin 8	Low-current load, 18.0 kΩ

Table 9: Alternative configurations for connecting load switch input and output

4.6.6 LDO bypass capacitors

LDO bypass capacitors are available when the load switches are in LDO mode.

For LDO mode connect jumpers between pin 3 and 4 on pin header **P16** for **LDO1**, and pin 1 and 2 for **LDO2**. The LDO schematic is shown in Figure 18: Load switch and LDO schematic on page 22.

PMIC pin	Connected configuration	Connected jumper pins
VOUTLDO1	LDO1	P16 pin 3 to pin 4
VOUTLDO2	LDO2	P16 pin 1 to pin 2

Table 10: Jumper configuration for LDO bypass capacitors

Note: Ensure the LDO bypass capacitors are disconnected when the load switches are not in LDO mode.

4.6.7 LED jumper connections

The nPM1300 EK has three LEDs for visualizing the status of the nPM1300 PMIC.

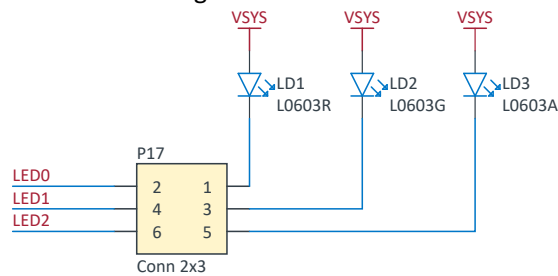

Figure 19: LED schematic

The PCB overlay show the default states for the LEDs. The LEDs can be configured in software for custom use.

Jumpers on pin header **P17** connects the LEDs on the EK to the PMIC LED pins. During current measurements, or if using external LEDs, the LEDs can be disconnected from the PMIC by removing the jumpers.

PMIC pin	Part	Function	Color	Connecting jumper pins
LED0	LD1	ERR (error)	Red	P17 pin 1 to pin 2
LED1	LD2	CHG (charging)	Green	P17 pin 3 to pin 4
LED2	LD3	HOST (host activity)	Amber	P17 pin 5 to pin 6

Table 11: Default PMIC LED pin configuration and corresponding LEDs on EK

4.7 Buttons

The nPM1300 EK has four push buttons.

The buttons short the following connected PMIC pins to ground.

Part	Parameter controlled (PMIC)	Function
SW1	SHPHLD/RESET	PMIC RESET / Exit Ship mode / Exit Hibernation mode
SW2	GPIO0	PMIC GPIO0
SW3	GPIO1	PMIC GPIO1
SW4	GPIO2	PMIC GPIO2

Table 12: nPM1300 EK buttons

4.8 nPM Controller

The nPM Controller circuit on the nPM1300 EK enables easy interaction with the PMIC through the nPM PowerUP app or a terminal.

To enable software control, connect **nPM CONTROLLER** on **J4** to a computer using a compatible USB-C cable (see [Minimum requirements](#) on page 9). To obtain a successful connection with the PMIC, make sure to power the PMIC first, or perform a power cycle on the nPM Controller. See [Connect and use the nPM1300 EK](#) to connect the EK and get started with the nPM PowerUP app.

A green LED (**LD4**) next to the nPM Controller shows the status of the nPM Controller connection with the PMIC. LED light patterns and nPM Controller status are shown in the following table.

LED light pattern (LD4)	nPM Controller status	Actions
Fading on/off	Successful connection with nPM1300 PMIC	Correctly powered PMIC and nPM Controller. No action needed.
Toggling on/off	No connection with nPM1300 PMIC	Incorrectly powered. Check if PMIC has power, or power cycle nPM Controller.

Table 13: LED pattern and corresponding nPM Controller status

4.9 nPM Fuel Gauge Board

The nPM Fuel Gauge Board is an easy-to-use extension board for the nPM1300 EK, allowing battery profiling and fuel gauging in the nPM PowerUP app.

To connect the nPM1300 EK to the nPM Fuel Gauge Board, use edge connectors **P20** and **P21** (denoted as **EXT BOARD**).

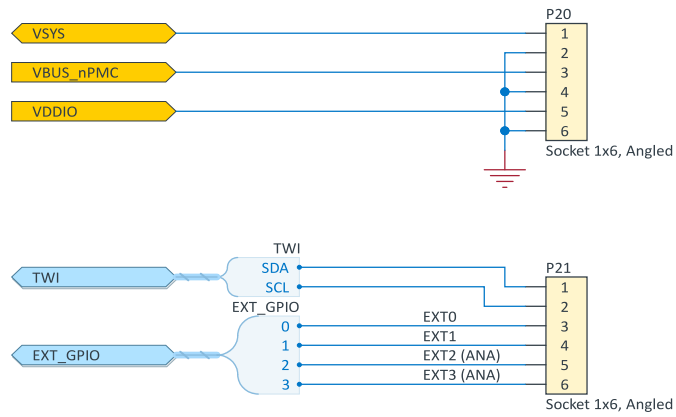

Figure 20: Schematic of extension board connections on EK

Pin	EXT BOARD connectors	
	P20	P21
1	VSYS	SDA
2	GND	SCL
3	VBUS_nPMC (nPM Controller)	EXT_GPIO0
4	GND	EXT_GPIO1 (active low)
5	VDDIO	EXT_GPIO2
6	GND	EXT_GPIO3

Table 14: Connected nets on the EXT BOARD connectors

For more information, see [nPM Fuel Gauge Board Hardware](#).

5 Connect and use the nPM1300 EK

The nPM1300 *EK* provides three distinct development levels that range from simple evaluation to complete implementation.

The following development alternatives are available:

- Evaluating the nPM1300 *PMIC* without writing any code or performing any device programming
- Using the EK together with a Nordic *DK* to evaluate the *PMIC* or develop your own nPM1300 application
- Using the EK together with your own custom hardware to evaluate the *PMIC* or develop your own *System on Chip (SoC)* application

5.1 Evaluate nPM1300 using nPM PowerUP

The nPM1300 *EK* provides connections for easy configuration and evaluation of the nPM1300 *PMIC* through the nPM PowerUP computer app available in [nRF Connect for Desktop](#).

With the nPM PowerUP app, you can use the built-in battery models or you can generate your own battery model by using the EK together with the [nPM Fuel Gauge Board](#). The generated battery model can be integrated with a host *SoC* for fuel gauging.

5.1.1 Connect the nPM1300 EK with nPM PowerUP

Set up the nPM1300 *EK* to start using the nPM PowerUP app.

1. To power the nPM1300 *PMIC*, connect a USB-C cable with 1.5 A current capability to **USB PMIC** on **J3**.
2. Insert the battery ensuring the correct polarity as shown on the EK. Depending on your battery, use one of the following alternatives:
 - a) For a battery with an integrated *NTC* thermistor, use the battery connector on **J2**.
 - b) For a battery without an integrated *NTC* thermistor, use the battery connector on **J1**. Connect a jumper between **NTC** (pin 2) and **10 kΩ** (pin 3) on pin header **P3** to use the integrated 10 kΩ resistor.
3. Use a USB-C cable with USB 2.0 High Speed compatibility to connect from your computer to **nPM CONTROLLER** on **J4**.

Use a ferrite bead around the USB cable to reduce electromagnetic interference.

A green LED light (**LD4**) indicates a successful connection with the [nPM Controller](#).

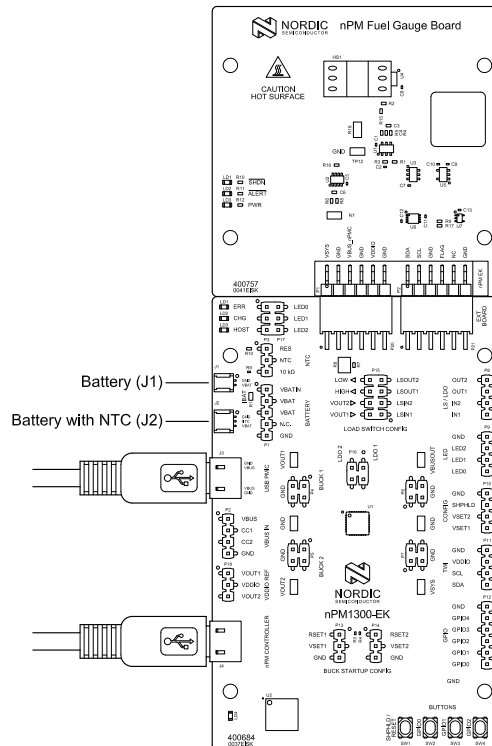

4. Select **nPM1300 Evaluation Kit** on the left-side panel in the nPM PowerUP app.
5. Select **Profile Battery** to profile your battery and generate a battery model.
6. Follow the instructions provided in the Profile Battery wizard and refer to [Using the nPM1300 Fuel Gauge](#) for further guidelines on battery profiling.

Warning: The heat sink on the Fuel Gauge Board can become hot during battery profiling. Allow the device to cool down before handling it post-profiling.



Drivers and sample applications for nPM1300 can be found in [nPM1300 Fuel gauge sample](#).

5.2 Use the nPM1300 EK with an nRF5340 DK

The nPM1300 EK can power the nRF5340 SoC as a host device on the nRF5340 DK.

Note: The EK only powers the nRF5340 SoC on the DK. To access the nRF5340 DK features such as flashing and debugging, the IMCU on the DK must be externally powered.

To connect and configure the EK with the nRF5340 DK:

1. Connect the nPM1300 EK to the nRF5340 DK according to the connection diagram.
2. On the DK, make sure the **VEXT→nRF** switch **SW10** is in the **ON** position. This connects the external supply to VDD (in this case, **VOU12** on the *PMIC*).

3. On the DK, make sure the **nRF POWER SOURCE** switch **SW9** is in the **VDD** position. This ensures that only the nRF5340 circuitry is powered from VDD.
4. To flash and debug nRF5340, connect a USB cable to the USB port **J2** on the DK. This only powers the IMCU used for flashing and debugging.
5. On the EK, disconnect the USB-C cable from **J4** to put the EK in standalone mode. This disables the nPM Controller.
6. Power the EK by connecting a desired power input source: VBUS, VBAT, or both.

Note: Both the nRF5340 host device and the PMIC have the same I/O reference level (**VOUT2**), therefore **VDDIO** is redundant and not connected between the EK and the DK.

The following figure and table show the connections between the EK and the nRF5340 DK. A similar setup might apply to the DKs of the nRF52-series or the nRF9160 DK (not covered in this user guide).

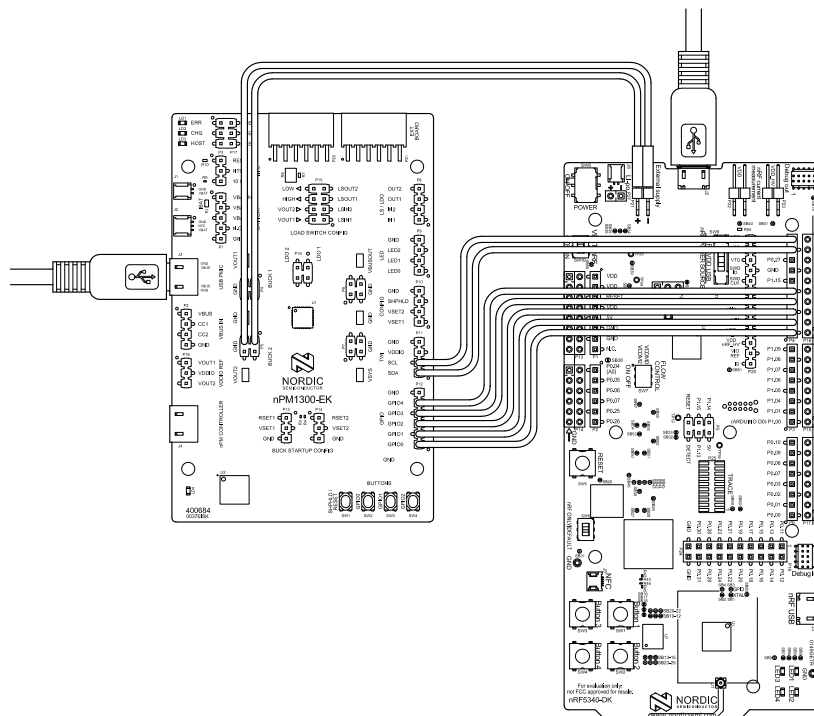

Figure 21: Connecting nPM1300 EK with nRF5340 DK

Function	nPM1300 EK		nRF5340 DK		Comment
	Pin name	Location	Pin name	Location	
Power	VOUT2	P5 pin 1	External supply + (positive)	P21 pin 1	3.0 V, use default VSET2 on EK
	GND	P5 pin 3	External supply - (negative)	P21 pin 2	Ground
TWI	SDA	P11 pin 1	P1 . 02	P4 pin 9	Connect to a TWI compliant GPIO on DK
	SCL	P11 pin 2	P1 . 03	P4 pin 10	Connect to a TWI compliant GPIO on DK
GPIO	GPIO0	P12 pin 1	P1 . 10	P4 pin 1	Connect to a GPIO on DK
	GPIO1	P12 pin 2	P1 . 11	P4 pin 2	Connect to a GPIO on DK
	GPIO2	P12 pin 3	P1 . 12	P4 pin 3	Connect to a GPIO on DK
	GPIO3	P12 pin 4	P1 . 13	P4 pin 4	Connect to a GPIO on DK
	GPIO4	P12 pin 5	P1 . 14	P4 pin 5	Connect to a GPIO on DK
Other	SHPHLD	P10 pin 3	P1 . 15	P4 pin 6	Connect to a GPIO on DK

Table 15: Connections between nPM1300 EK and nRF5340 DK

5.3 Use the nPM1300 EK with custom hardware

When the nPM1300 EK is used with custom hardware make sure they are compatible in terms of voltage and current specifications.

The configuration process is similar to the nRF5340 DK, however, board specific steps will deviate.

Note: If the host device on the custom hardware and the nPM1300 PMIC have different I/O reference levels, VDDIO on the EK must be supplied by the custom hardware.

6 Measure current

The nPM1300 EK can be set up to monitor current flowing into the nPM1300 PMIC, to and from the battery, and into the external application.

Note: The battery charger includes automatic trickle charge control which introduces restrictions on the type of current measurement instrument used to measure **VBAT**.

Current can be measured using any of the following test instruments.

- Power analyzer, uni/bidirectional capability
- Oscilloscope, bidirectional capability
- Ampere meter, bidirectional capability
- [Power Profiler Kit II \(PPK2\)](#), unidirectional capability
- *SMU*

For higher precision results we recommend the use of an SMU on both input and output parameters. The PPK2 is an affordable alternative to an SMU because it captures traces of both voltage and current changes. When using a PPK2 there is no need to connect an external resistor on the EK. Some attention to the EK is needed to measure current on an output using a series resistor.

For measurement instructions, see sections [Use an oscilloscope for current measurements](#) on page 32, [Use an ampere meter for current measurements](#) on page 33, and [Use a Power Profiler Kit II for current measurements](#) on page 35.

The main power supply for the nPM1300 PMIC is **VBUS**. The complementary power supply, as well as charger output, is **VBAT**. The PMIC regulated outputs are **VOUT1** and **VOUT2**. The unregulated outputs are **VBUSOUT** and **VSYS**.

Component	VBUS	VBAT	VOUT1	VOUT2
Measurement connector	P2, pin 1	P1, pin 1 and pin 2	P4, pin 1 and pin 2 or VOUT1 probe loop	P5, pin 1 and pin 2 or VOUT2 probe loop
Series resistor	External	R1 (IBAT)	External	External
Series resistor range	<100 mΩ	<100 mΩ	<100 mΩ	<100 mΩ
Directionality	Unidirectional	Bidirectional	Unidirectional	Unidirectional

Table 16: Components for current measurement

The nPM1300 EK has a default jumper configuration, see [Jumpers](#) on page 19. To allow the EK to work directly without changes make sure the jumpers are correct before powering up the EK. Prior to measurements, connect the EK to a DC power source (**VBUS**), see [Power supply](#) on page 13 for details.

For more information on current measurement, see the tutorial [Current measurement guide: Introduction](#).

6.1 Use an oscilloscope for current measurements

An oscilloscope measures the voltage drop across a current-measurement resistor. Set up the *EK* and oscilloscope according to the supply or output that you want to measure.

6.1.1 Prepare for VBAT current measurements

Mount a current-measurement resistor on the *EK* to measure the current on **VBAT** with an oscilloscope.

For **VBAT** current measurements:

- Mount an **IBAT** current-measurement resistor on **R1**. The recommended value is 100 mΩ or lower, to avoid issues with the *PMIC*'s automatic trickle charge feature and to reduce voltage error.
- Disconnect the jumper between **VBAT** and **VBATIN**.
- Use **P1** pin 1 (**VBATIN**) and pin 2 (**VBAT**) as probe points for performing **VBAT** current measurements.
- Make sure the oscilloscope supports bidirectional measurements.

To restore the *EK* to default jumper settings after measurements, connect the jumper between **VBAT** and **VBATIN** across pin 1 and pin 2 on **P1** and demount the **IBAT** series resistor.

6.1.2 Prepare for VBUS and VOUT current measurements

To measure the current on **VBUS**, **VOUT1**, or **VOUT2** with an oscilloscope, measure the voltage across an external current-measurement resistor (not mounted).

For **VBUS** current measurement:

- Connect a suitable current-measurement resistor between the source and **VBUS** pin 1 on **P2**.
- Connect **GND** pin 4 on **P2** to the source ground to ensure proper system grounding.

For **VOUT1** current measurement:

- Connect a suitable current-measurement resistor between the load and **VOUT1** pin 1 (or pin 2) on **P4**.
- Connect **GND** pin 3 (or pin 4) on **P4** to the load ground to ensure proper system grounding.

For **VOUT2** current measurement:

- Connect a suitable current-measurement resistor between the load and **VOUT2** pin 1 (or pin 2) on **P5**.
- Connect **GND** pin 3 (or pin 4) on **P5** to the load ground to ensure proper system grounding.

Note: It is recommended to use standard jumper wires compatible with 2.54 mm (0.1") headers. Make sure the jumper wires are rated for the current.

6.1.3 Measure VBAT, VBUS, and VOUT using an oscilloscope

Measure the current with an oscilloscope by probing the voltage drop across a current-measurement resistor.

Make sure you have prepared the *EK* for the given oscilloscope measurement case, as described in [Prepare for VBAT current measurements](#) on page 32 and [Prepare for VBUS and VOUT current measurements](#) on page 32.

Measurement steps:

1. Connect an oscilloscope in differential mode (or a similar mode) with two probes across the probe points of interest, depending on the measurement case prepared initially.

The following figure shows the **VBAT** current-measurement case, with probe points across the **IBAT** resistor between pins 1 and 2 on **P1**.

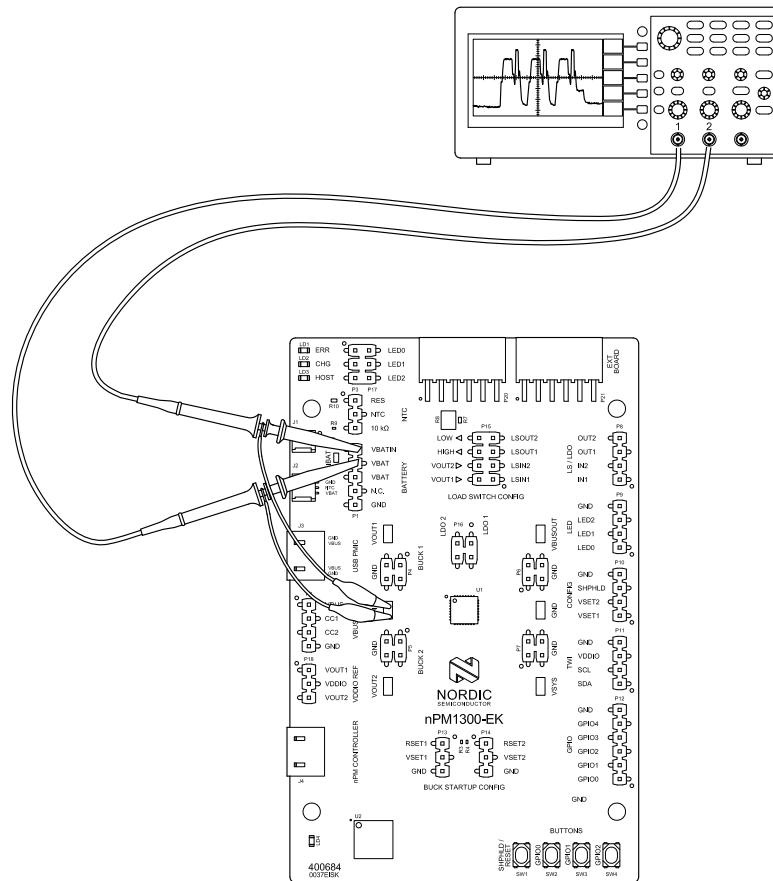

- Plot the voltage drop measured across the probe points and calculate the current. The measured voltage drop across the resistor is proportional to the current, depending on the resistance. For instance, a 100 mΩ resistor causes a 0.1 mV drop for each 1 mA drawn by the current being measured. The current can be averaged or integrated to analyze current and energy consumption over a period. A minimum of one sample every 5 μs is needed to accurately measure the average current.

Noise can be reduced by doing the following:

- Use X1 passive probes (no attenuation)
- Enable averaging mode (to reduce random noise)
- Enable high resolution function, if available
- Use an active differential probe across the resistor

6.2 Use an ampere meter for current measurements

An ampere meter can measure the average current flow. This method monitors the current flow by placing the ampere meter in series with the source (or load) and the probe-point. For an ampere meter the current-measurement resistor is integrated in the meter.

6.2.1 Prepare for VBAT, VBUS, and VOUT current measurements

Set up the *EK* and ampere meter according to the supply or output that you want to measure.

For **VBAT** current measurements:

- Ensure there is no **IBAT** current-measurement resistor mounted on **R1**.
- Disconnect the jumper between **VBAT** and **VBATIN**.
- Use bidirectional capable current measurement equipment as current flow on **VBAT** is bidirectional.

- The automatic trickle charge feature requires the impedance of the measurement circuit to be constant and less than 100 m Ω . Auto ranging multimeters can automatically change resistance depending on their range, this can trigger the error state of the charger.
- Use **P1** pin 1 (**VBATIN**) and pin 2 (**VBAT**) as probe points for performing **VBAT** current measurements.

For **VBUS** current measurements:

- Connect the ampere meter between the source and **VBUS** pin 1 on **P2**.
- Connect **GND** pin 4 on **P2** to the source ground to ensure proper system grounding.

For **VOUT1** current measurements:

- Connect the ampere meter between the load and **VOUT1** pin 1 (or pin 2) on **P4**.
- Connect **GND** pin 3 (or pin 4) on **P4** to the load ground to ensure proper system grounding.

For **VOUT2** current measurements:

- Connect the ampere meter between the load and **VOUT2** pin 1 (or pin 2) on **P5**.
- Connect **GND** pin 3 (or pin 4) on **P5** to the load ground to ensure proper system grounding.

Note: It is recommended to use standard jumper wires compatible with 2.54 mm (0.1") headers. Make sure the jumper wires are rated for the high currents.

6.2.2 Measure VBAT, VBUS, and VOUT using an ampere meter

Measure the current with an ampere meter by placing the ampere meter in series with the source or load and the probe point.

Make sure you have prepared the *EK* as described in [Prepare for VBAT, VBUS, and VOUT current measurements](#) on page 33.

1. Connect an ampere meter to the probe-point of interest, depending on the measurement case prepared initially.
2. Read the current value on the ampere meter.

The following figure shows the **VBAT** current-measurement case, with the ampere meter connected between **P1** pins 1 and 2.

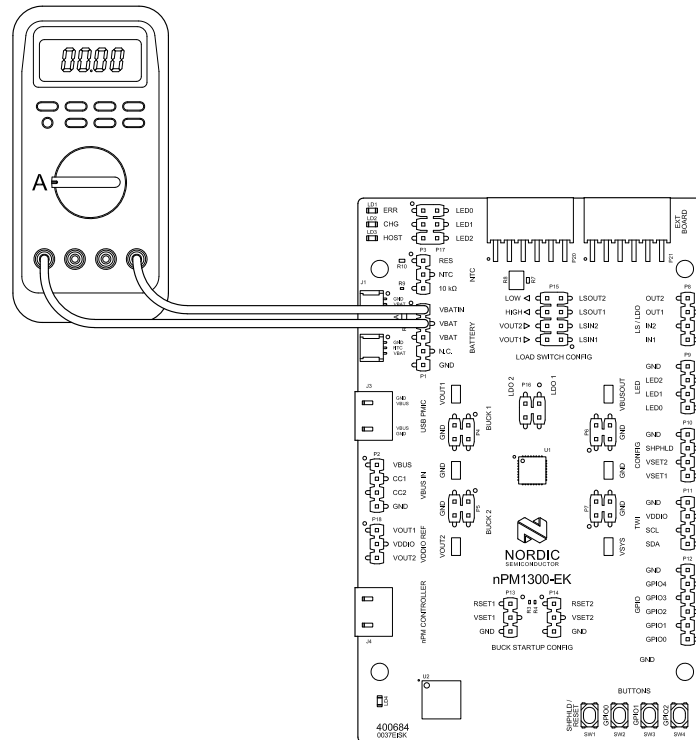

Figure 22: Current measurements with an ampere meter

6.3 Use a Power Profiler Kit II for current measurements

The average and instantaneous current flow can be measured using the Power Profiler Kit II (PPK2). No attention to series resistors is needed.

Set PPK2 in Ampere Meter mode to measure the power outputs (**VOUT1** and **VOUT2**) and in Source Meter mode to measure power inputs (**VBAT** and **VBUS**).

In Source Meter mode the power supply for the nPM1300 EK is from PPK2. In Ampere Meter mode the power for the EK is from an external source, with PPK2 placed in series between the EK and the load.

PPK2 measurement mode	Parameters	Description
Ampere Meter	VOUT1	Power outputs (BUCK outputs) measured with the PPK2 in series between the output and the load.
	VOUT2	
Source Meter (supply)	VBAT	Power inputs (supplies) measured with the PPK2 as the power source into the EK.
	VBUS	

Table 17: Measurement modes for PPK2

For more information on the PPK2, see the [Power Profiler Kit II](#).

6.3.1 Measure VBAT current

The Power Profiler Kit II (PPK2) is operated in Source Meter mode for this configuration.

1. Connect the PPK2 to the nPM1300 EK with the 4-pin measurement cable using the following pins:
 - PPK2 **GND** to nPM1300 EK **GND** on **P1** (pin 5)
 - PPK2 **VOU** to nPM1300 EK **VBAT** on **P1** (pin 3)

2. Make sure a jumper is connected between **VBATIN** and **VBAT** on **P1** (pins 1 and 2).
3. Connect the load (nRF5340 *DK* in this example) to **VOUT1** (pin 1 or 2) and **GND** (pin 3 or 4) on nPM1300 EK **P4**.

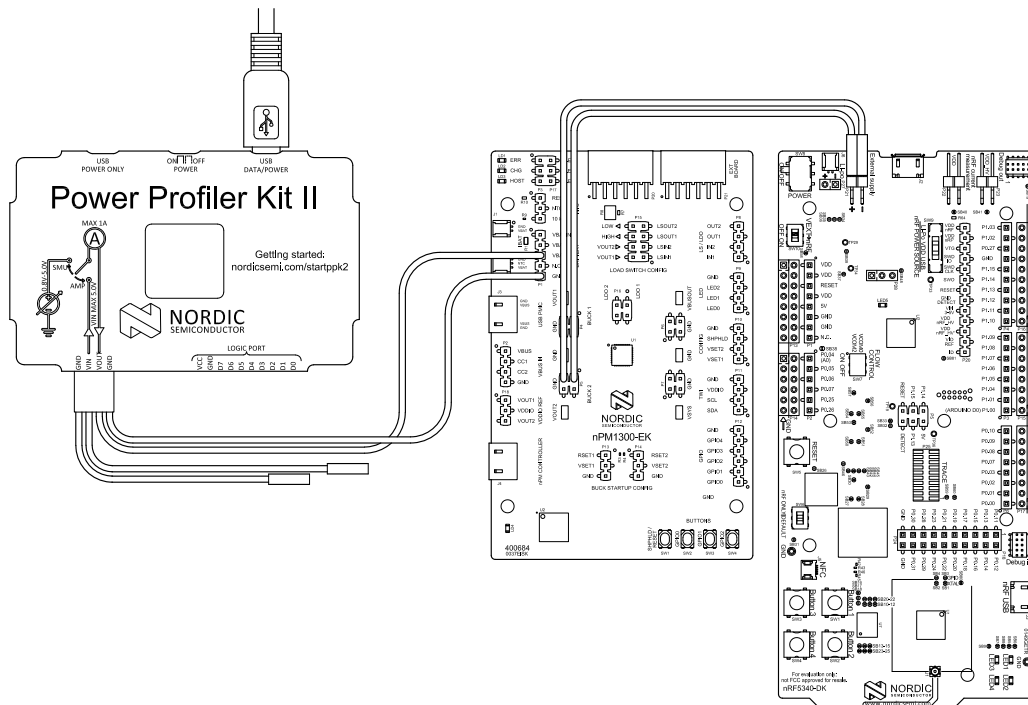

4. Connect the PPK2 to a computer using a USB cable.
5. Start the Power Profiler app.
6. Select your PPK2.
7. Select **Source Meter** as the mode.
8. Set the supply voltage to value between 2.3 V to 4.45 V.
9. Toggle **Enable power output** to power the nPM1300 EK.
10. Click **Start**.

6.3.2 Measure VBUS current

The Power Profiler Kit II (PPK2) is operated in Source Meter mode for this configuration.

1. Connect the PPK2 to the nPM1300 *EK* with the 4-pin measurement cable using the following pins:
 - PPK2 **GND** to nPM1300 EK **GND** on **P2** (pin 4)
 - PPK2 **VOUT** to nPM1300 EK **VBUS** on **P2** (pin 1)
2. Connect the load (nRF5340 *DK* in this example) to **VOUT1** (pin 1 or 2) and **GND** (pin 3 or 4) on nPM1300 EK **P4**.

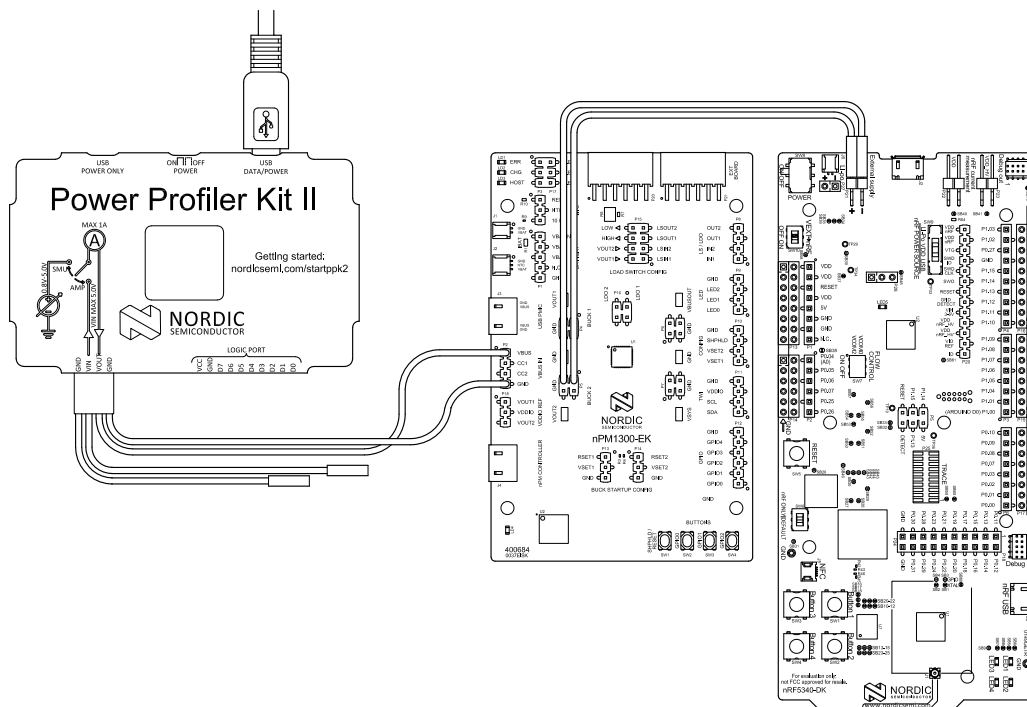

3. Connect the PPK2 to a computer using a USB cable.
4. Start the Power Profiler app.
5. Select your PPK2.
6. Select **Source Meter** as the mode.
7. Set the supply voltage to a value between 4.0 V to 5.5 V.
8. Toggle **Enable power output** to power the nPM1300 EK.
9. Click **Start**.

6.3.3 Measure VOUT1 or VOUT2 current

The Power Profiler Kit II (PPK2) is operated in Ampere Meter mode for this configuration.

Use a 4-pin cable for the pin connection between PPK2, nPM1300 EK, and the target device (nRF5340 DK in this example).

1. Connect the PPK2 **GND** to nPM1300 EK **GND**. Depending on what you want to measure, use the following alternatives on the EK:
 - a) **VOUT1**: use **P4** (pins 3 or 4)
 - b) **VOUT2**: use **P5** (pins 3 or 4)
2. Connect the PPK2 **VIN** to nPM1300 EK using the following alternatives:
 - a) **VOUT1**: use **P4** (pins 1 or 2)
 - b) **VOUT2**: use **P5** (pins 1 or 2)
3. Connect the PPK2 to the target device (nRF5340 DK in this example) on the following pins:
 - PPK2 **VOUT** to DK External supply
 - PPK2 **GND** to DK External supply

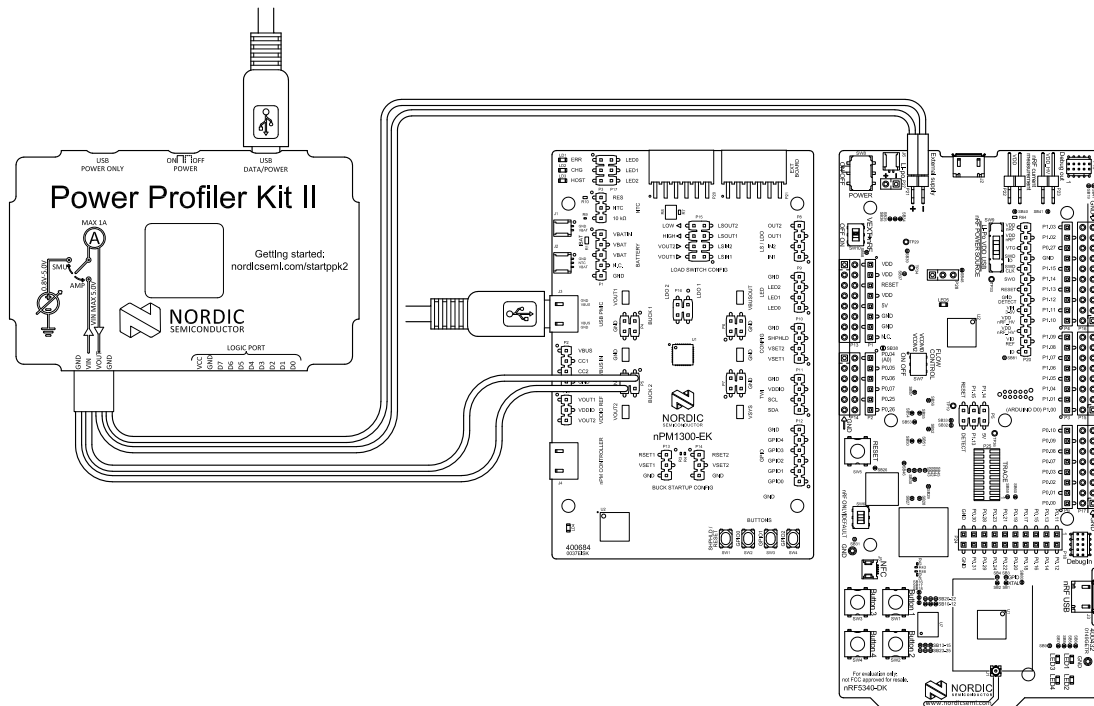

4. Connect the PPK2 to a computer using a USB cable.
5. Connect the nPM1300 EK to a computer using a USB cable.
6. Start the Power Profiler app.
7. Select your PPK2.
8. Select **Ampere Meter** as the mode.
9. Toggle **Enable power output** to power the target device (nRF5340 DK in this example).
10. Click **Start**.

Glossary

Application Programming Interface (API)

A language and message format used by an application program to communicate with an operating system, application, or other service.

DC

Direct Current

Development Kit (DK)

A hardware development platform used for application development.

Electrostatic Discharge (ESD)

A sudden discharge of electric current between two electrically charged objects.

Evaluation Kit (EK)

A platform used to evaluate different development platforms.

General-Purpose Input/Output (GPIO)

A digital signal pin that can be used as input, output, or both. It is uncommitted and can be controlled by the user at runtime.

Inter-integrated Circuit (I²C)

A multi-master, multi-slave, packet-switched, single-ended, serial computer bus.

Low-Dropout Regulator (LDO)

A linear voltage regulator that can operate even when the supply voltage is very close to the desired output voltage.

Negative Temperature Coefficient (NTC)

A negative temperature coefficient refers to materials where there is a decrease in electrical resistance when their temperature is raised.

Power Management Integrated Circuit (PMIC)

A chip used for various functions related to power management.

Printed Circuit Board (PCB)

A board that connects electronic components.

Pulse Width Modulation (PWM)

A form of modulation used to represent an analog signal with a binary signal where the switching frequency is fixed, and all the pulses corresponding to one sample are contiguous in the digital signal.

Software Development Kit (SDK)

A set of tools used for developing applications for a specific device or operating system.

Source Measure Unit (SMU)

An electronic instrument that is capable of both sourcing and measuring at the same time.

System on Chip (SoC)

A microchip that integrates all the necessary electronic circuits and components of a computer or other electronic systems on a single integrated circuit.

Universal Serial Bus (USB)

An industry standard that establishes specifications for cables and connectors and protocols for connection, communication, and power supply between computers, peripheral devices, and other computers.

Recommended reading

In addition to the information in this document, you may need to consult other documents.

Nordic documentation

- [nPM1300 Product Specification](#)
- [nPM Fuel Gauge Board Hardware](#)
- [Using the nPM1300 Fuel Gauge](#)
- [nPM1300 EK product page](#)
- [nPM Fuel Gauge Board product page](#)

Legal notices

By using this documentation you agree to our terms and conditions of use. Nordic Semiconductor may change these terms and conditions at any time without notice.

Liability disclaimer

Nordic Semiconductor ASA reserves the right to make changes without further notice to the product to improve reliability, function, or design. Nordic Semiconductor ASA does not assume any liability arising out of the application or use of any product or circuits described herein.

Nordic Semiconductor ASA does not give any representations or warranties, expressed or implied, as to the accuracy or completeness of such information and shall have no liability for the consequences of use of such information. If there are any discrepancies, ambiguities or conflicts in Nordic Semiconductor's documentation, the Product Specification prevails.

Nordic Semiconductor ASA reserves the right to make corrections, enhancements, and other changes to this document without notice.

Life support applications

Nordic Semiconductor products are not designed for use in life support appliances, devices, or systems where malfunction of these products can reasonably be expected to result in personal injury.

Nordic Semiconductor ASA customers using or selling these products for use in such applications do so at their own risk and agree to fully indemnify Nordic Semiconductor ASA for any damages resulting from such improper use or sale.

RoHS and REACH statement

Complete hazardous substance reports, material composition reports and latest version of Nordic's REACH statement can be found on our website www.nordicsemi.com.

Trademarks

All trademarks, service marks, trade names, product names, and logos appearing in this documentation are the property of their respective owners.

Copyright notice

© 2025 Nordic Semiconductor ASA. All rights are reserved. Reproduction in whole or in part is prohibited without the prior written permission of the copyright holder.

