

nPM1100 EK Hardware

v1.0.0

User Guide

Contents

Revision history	iii
1 Introduction	4
2 Minimum requirements	5
3 Kit content	6
4 Hardware description	8
4.1 Hardware figures	8
4.2 Block diagram	9
4.3 Power supply	9
4.4 LEDs	10
4.5 Switches	11
4.5.1 Charge voltage termination	11
4.5.2 Charge current limit	11
4.5.3 Output voltage configuration	11
4.5.4 Buck regulator mode	12
4.5.5 VBUS current limit	12
4.6 Buttons	13
4.6.1 Ship mode activation	13
4.6.2 Ship mode disabling	13
4.7 Solder bridge configuration	13
4.8 NTC configuration	13
5 Measuring current	15
5.1 Preparing the nPM1100 EK	15
5.1.1 Preparing for VBUS current measurements	16
5.1.2 Preparing for VBAT current measurements	16
5.1.3 Preparing for VOUTB current measurements	16
5.2 Using an oscilloscope for current profile measurement	17
5.3 Using an ampere meter for current measurements	18
5.4 Using the Power Profiler Kit II for current measurements	18
5.4.1 Measuring VBUS current	18
5.4.2 Measuring VBAT current	19
5.4.3 Measuring VOUTB current	20
Glossary	21
Acronyms and abbreviations	22
Recommended reading	23
Legal notices	24

Revision history

Date	Description
2023-02-15	Updated the following: <ul style="list-style-type: none">• Introduction on page 4• Kit content on page 6• Hardware description on page 8• Charge voltage termination on page 11• Hardware drawings based on nPM1100 EK (HIGH VTERM) v1.0.0• Editorial changes
2021-09-28	Updated the following: <ul style="list-style-type: none">• Hardware drawings based on nPM1100 EK v1.0.0• Power supply on page 9• Output voltage configuration on page 11
2021-05-27	First release

1 Introduction

The nPM1100 EK is a hardware platform used to evaluate the nPM1100 *Power Management Integrated Circuit (PMIC)*.

The key features of the *Evaluation Kit (EK)* are:

- nPM1100 EK *PMIC*
- Lithium-ion/lithium-polymer USB battery charger
- High efficiency step-down buck regulator
- Power supply from USB, pins, or battery
- DIP Switches to set:
 - Step-down regulator output voltage
 - Charge current
 - Charge termination voltage
 - USB current limit
 - BUCK operating mode
- Buttons for entering/leaving Ship mode
- Headers for connecting to configuration pins
- Pins for measuring current flow

This user guide covers the following product options for the EK:

- nPM1100 EK—standard battery charging termination volume
- nPM1100 EK (HIGH VTERM)—high battery charging termination volume

For access to hardware schematics and layout files, see [nPM1100 EK product page](#).



Environmental Protection

Waste electrical products should not be disposed of with household waste.

Please recycle where facilities exist. Check with your local authority or retailer for recycling advice.

2 Minimum requirements

Before you start, check that you have the required hardware.

Hardware requirements

- Power supply, USB or connector
- Micro-USB 2.0 cable

3 Kit content

The nPM1100 EK consists of hardware, reference design files, and documentation.

The EK only comes with the board. You need to provide your own Micro-USB cable.

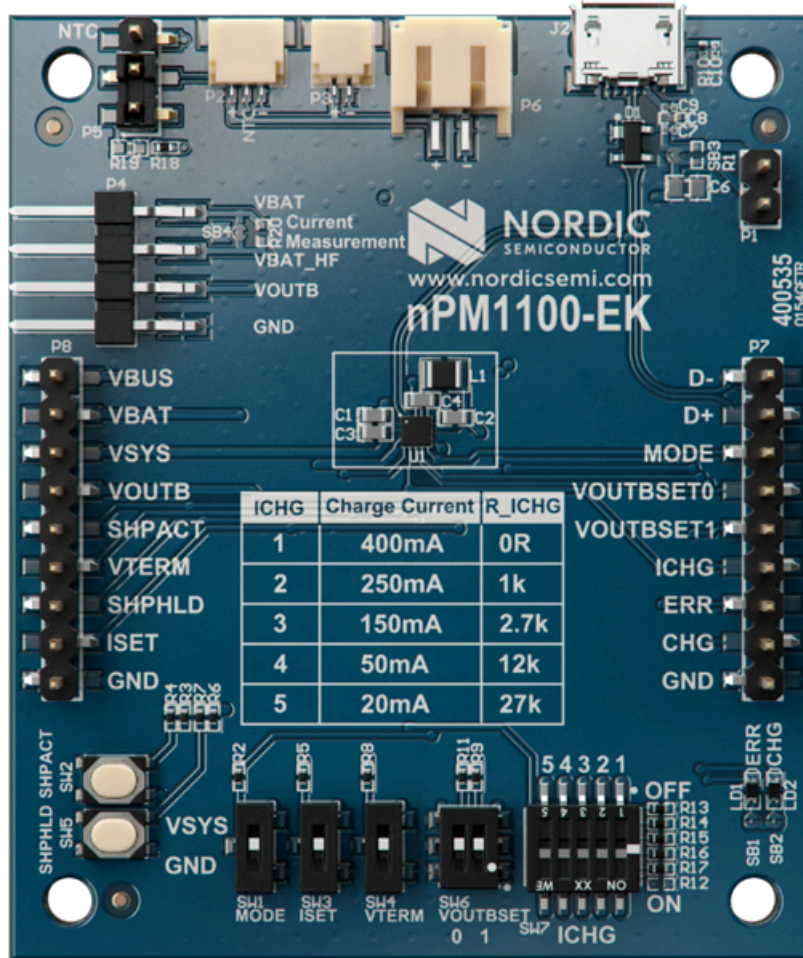

Figure 1: nPM1100 EK (standard)

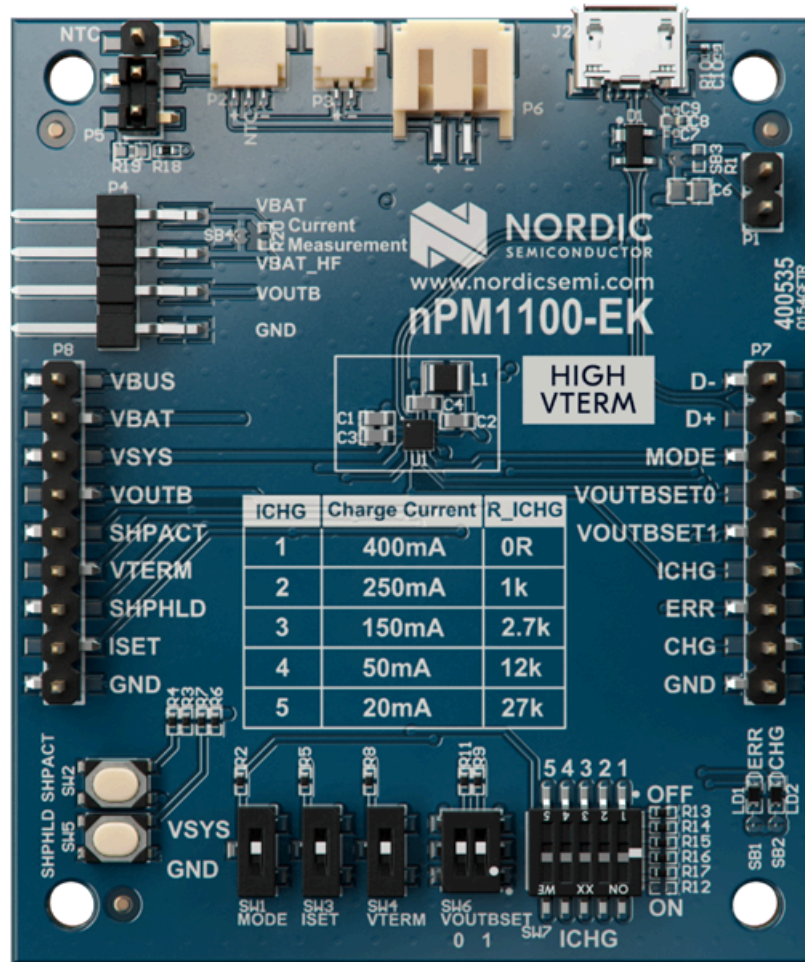

Figure 2: nPM1100 EK (HIGH VTERM)

Hardware files

The hardware design files including schematics, PCB layout files, bill of materials, and Gerber files for the nPM1100 EK are available on the [nPM1100 EK product page](#).

4 Hardware description

The nPM1100 EK allows full flexibility for configuration of the nPM1100 PMIC without having to make any hardware modifications. The EK supports Primary Detection of the USB port type based on the [USB Battery Charging Specification](#).

Alternatively, the current limitation can be controlled manually by a switch. The current limitation switch can only override from a 100–500 mA limit for a *Standard Downstream Port (SDP)* detection. It cannot override or limit a 500 mA *Dedicated Charging Port (DCP)* down to 100 mA.

The battery charge termination voltage depends on the EK product option.

4.1 Hardware figures

The nPM1100 EK hardware drawings show both sides of the EK.

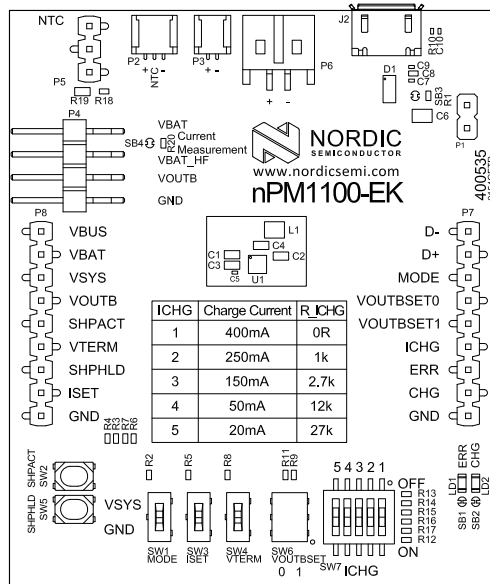

Figure 3: nPM1100 EK front view

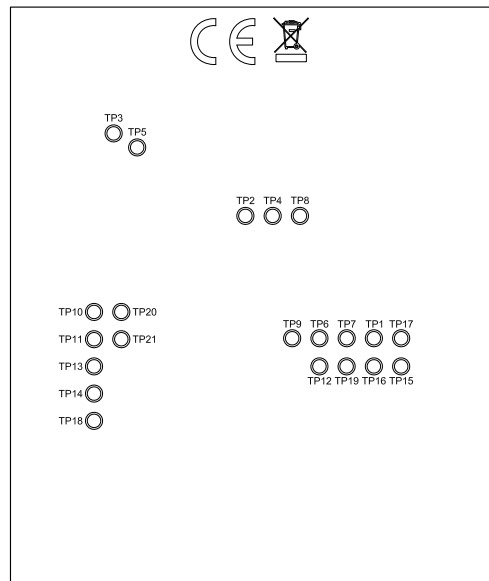

Figure 4: nPM1100 EK back view

4.2 Block diagram

The block diagram illustrates the nPM1100 EK functional architecture.

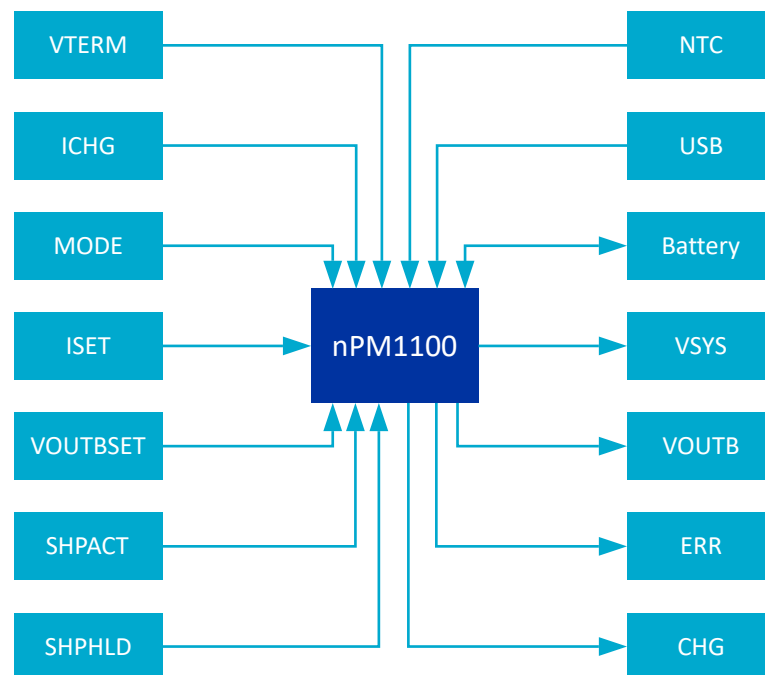

Figure 5: nPM1100 EK block diagram

4.3 Power supply

The nPM1100 EK has a flexible and configurable power supply system to allow testing with different power sources and to facilitate accurate power measurements.

The power options are:

- USB connector **J2** (5.0 V)

- VBUS **P8** pin 1 (4.5–6.7 V)
- Connectors for Li-ion/Li-poly batteries **P2**, **P3**, **P6** or **P4** pin 1 (2.5–4.2 V)

Note: Use only one connector at a time.

Use the USB connector or the VBUS pin for powering the system and delivering power when charging. The nPM1100 PMIC will pull current from the battery if no external power source is connected to **J2/P4**.

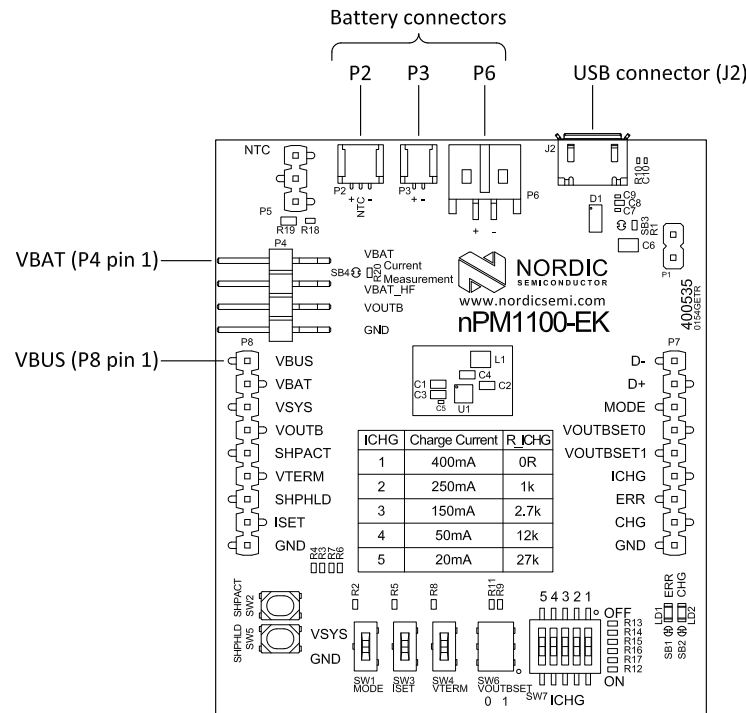

Figure 6: Power supply options

Note: Before connecting a battery, make sure the battery plug polarity matches the nPM1100 EK design.

4.4 LEDs

The nPM1100 EK has two LEDs for visualizing the status of the nPM1100 battery charger. Both can be disconnected for power consumption measurements.



Figure 7: LED schematic

Part	Function	Solder bridge
LD1	Error indication, ERR	SB1, cut to disconnect LD1
LD2	Charge active indication, CHG	SB2, cut to disconnect LD2

Table 1: LED connection

4.5 Switches

The nPM1100 EK has several switches to configure the nPM1100 device. All switches have series resistors to allow the onboard switches to be overridden by external input.

4.5.1 Charge voltage termination

SW4 controls the charge voltage termination.

The battery charge termination voltage depends on the *EK* product option. The EK options and their corresponding charge voltage termination parameters are given in the following table.

Switch	Function	Parameter controlled	EK product option	V_{TERM}	
				VTERMSET = LOW	VTERMSET = HIGH
SW4	Charge voltage termination	VTERMSET	nPM1100 EK Standard VTERM	4.10 V	4.20 V
			nPM1100 EK HIGH VTERM	4.25 V	4.35 V

Table 2: Charge voltage termination parameters

4.5.2 Charge current limit

SW7 controls the maximum charge current limit.

Switch	Function	Parameter controlled
SW7	Charge current limit	ICHG

Table 3: Charge current limit parameters

SW7 is a 5-pole dip switch that can select the five defined current limits in the following table. This is done by setting the resistance from ICHG to GND. Closing multiple switches simultaneously decreases the resistance and increases the current limit. The user configured current limit can be set by leaving all switches open and selecting an appropriate R12 value.

ICHG	Charge current	R_ICHG
1	400 mA	0 Ω
2	250 mA	1.0 k Ω
3	150 mA	2.7 k Ω
4	50 mA	12 k Ω
5	20 mA	27 k Ω

Table 4: SW7 current limits

4.5.3 Output voltage configuration

SW6 controls the nPM1100 step-down regulator output voltage.

Switch	Function	Parameter controlled
SW6A	Output Voltage configuration	VOUTBSET1
SW6B		VOUTBSET0

Table 5: Output voltage configuration parameters

SW6 is a 2-pole dip switch used to support four defined output voltage levels.

VOUTBSET0/SW6B	VOUTBSET1/SW6A	VOUTB
GND	GND	1.8 V
VSYS	GND	2.1 V
GND	VSYS	2.7 V
VSYS	VSYS	3.0 V

Table 6: SW6 output voltage levels

4.5.4 Buck regulator mode

SW1 controls the operating mode of the buck regulator.

Switch	Function	Parameter controlled
SW1	Buck regulator mode control	MODE

Table 7: Buck regulator configuration parameters

The nPM1100 buck regulator supports two operating modes and **SW1** selects which mode to use.

SW1	Buck mode
GND	Automatic
VSYS	PWM mode

Table 8: Buck regulator operating modes

4.5.5 VBUS current limit

SW3 controls the VBUS current limit.

Switch	Function	Parameter controlled
SW3	VBUS current limit configuration	ISET

Table 9: VBUS current limit parameters

ISET can override the 100 mA current limit when a USB cable is not used or a USB SDP is detected.

4.6 Buttons

The nPM1100 EK has two buttons used to control the device. All buttons have series resistors to allow external input to override the onboard buttons.

4.6.1 Ship mode activation

Activate ship mode by pushing **SW2**.

Button	Function	Parameter controlled
SW2	Ship mode activation	SHPACT

Table 10: Ship mode activation parameters

4.6.2 Ship mode disabling

Disable ship mode by pushing **SW5**.

Button	Function	Parameter controlled
SW5	Ship mode disabling	SHPHLD

Table 11: Ship mode disabling parameters

4.7 Solder bridge configuration

The nPM1100 EK has multiple solder bridges for enabling or disabling functionality on the *EK*. Changes to the solder bridges are not needed for normal use of the *EK*.

The following table is a complete overview of the solder bridges on the nPM1100 EK.

Solder bridge	Default	Function
SB1	Closed	Cut to disconnect ERR LED
SB2	Closed	Cut to disconnect CHG LED
SB3	Closed	Cut to allow measurement of VBUS current
SB4	Closed	Cut to allow measurement of VBAT current

Table 12: Solder bridge configuration

4.8 NTC configuration

The nPM1100 *PMIC* implements thermal protection based on battery temperature via the **NTC** pin.

When using a battery pack with an integrated thermistor, battery connector **P2** should be used and header **P5** should be left unconnected.

When using a battery pack without an integrated thermistor or when using connector **P3**, **P6**, or **P8** pin 2, a 10 kΩ onboard resistor can be used instead of a thermistor by shorting **P5** pin 2 and pin 3.

Optionally, a thermistor can also be mounted onboard via **R19** footprint. **P5** pins 1 and 2 must be shorted together to connect the thermistor.

If there is no NTC in the battery pack and the **P5** header is not adjusted, charging will not occur and the CHG LED will not light up.

5 Measuring current

The nPM1100 EK supports the monitoring of current flowing into the *PMIC*, to and from the battery, and into the external application .

Note: The battery charger includes automatic trickle charge control which introduces restrictions on what current measurement instruments can be used with VBAT.

Current can be measured using various test instruments. Some examples of test equipment are the following:

- Power analyzer, uni/bidirectional capability
- Oscilloscope, bidirectional capability
- Ampere meter, bidirectional capability
- Power Profiler Kit II (PPK2), unidirectional capability

The nPM1100 *PMIC* primary power supply is from **VBUS**. The secondary power supply as well as charger output is **VBAT**.

The nPM1100 *PMIC* primary output is **VOUTB**.

Component	VBUS	VBAT	VOUTB
Measurement connector	P8, pin 1	P4, pins 1 and 2	P4, pin 3
Solder bridge	SB3	SB4	
Series resistor	R1	R20	
Series resistor range	<100 mΩ	<100 mΩ	
Directionality	Unidirectional	Bidirectional	Unidirectional

Table 13: Components for current measurement

For more information on current measurement, see the tutorial [Current measurement guide: Introduction](#).

5.1 Preparing the nPM1100 EK

To measure current, you must first prepare the *EK*.

The nPM1100 EK is configured to work directly without changes when powering up. To enable current measurement on an output, cut the associated solder bridge.

Changes are not needed when using the PPK2.

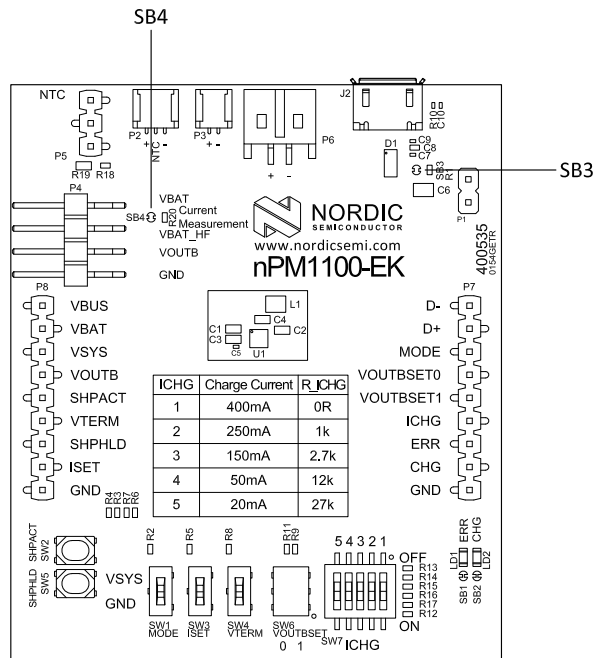

Figure 8: Prepare the EK for current measurements

5.1.1 Preparing for VBUS current measurements

You can prepare the *EK* for measuring VBUS current based on different scenarios.

To prepare the *EK*:

- To use **P1** as a probe-point for performing current measurement on VBUS, cut the PCB track shorting solder bridge **SB3**.
- To use an oscilloscope for measurements, mount a series resistor on **R1**. The recommended resistance value is 100 mΩ.

To restore normal kit functionality after measurements, solder **SB3**, add a 0 Ω resistor on **R1** or apply a jumper on **P1**.

5.1.2 Preparing for VBAT current measurements

You can prepare the *EK* for measuring VBAT current based on different scenarios.

To prepare the *EK*:

- To use **P4** as a probe-point for performing current measurement on VBAT, cut the PCB track shorting solder bridge **SB4**.
- Use bidirectional capable current measurement equipment because current flow on VBAT is bidirectional.
- The automatic trickle charge feature requires the impedance of the measurement circuit to be constant and less than 100 mΩ. Autoranging multimeters may automatically change resistance depending on range, this may lead to the error state of the charger to trigger.
- Mount the series resistor on **R20** to use an oscilloscope for measurements. The recommended value is 100 mΩ or lower.

To restore normal kit function after measurement, solder **SB4**, add a 0 Ω resistor on **R20**, or apply a jumper across pins 1 and 2 on **P4**.

5.1.3 Preparing for VOUTB current measurements

Connect the measurement circuit between VOUTB on **P4** pin 3 and the external load.

5.2 Using an oscilloscope for current profile measurement

Battery current profile can be measured using an oscilloscope with a differential probe across a shunt resistor. The voltage drop across the resistor will be proportional to the current flow. An oscilloscope can then measure the average current over a given time and capture the current profile.

Make sure you have prepared the *EK* as described in [Preparing the nPM1100 EK](#) on page 15.

1. Mount a shunt resistor within the acceptable range on the series resistor footprint for the signal of interest.
2. Connect an oscilloscope in differential mode or a similar mode with two probes on the pins of the measurement connector for the signal of interest.

Note: [Table 13: Components for current measurement](#) on page 15 provides more information on the components used for the steps above.

3. Calculate or plot the instantaneous current from the voltage drop across the resistor by taking the difference of the voltages measured on the two probes. The voltage drop will be proportional to the current. For instance, a 100 mΩ resistor will cause a 0.1 mV drop for each 1 mA drawn by the circuit being measured.

The plotted voltage drop can be used to calculate the current at a given point in time. The current can then be averaged or integrated to analyze current and energy consumption over a period.

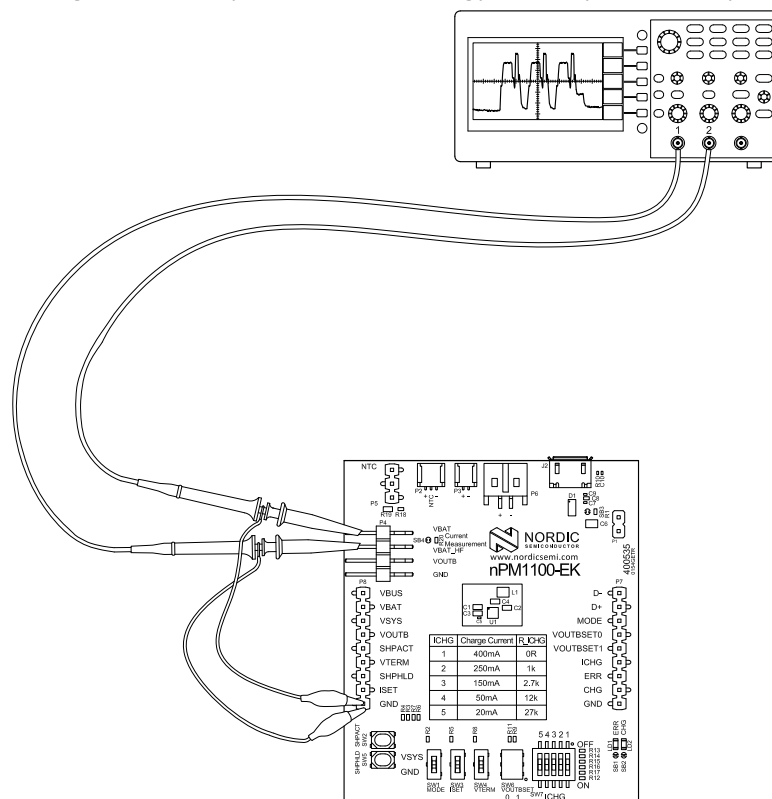

Figure 9: VBAT current measurement with an oscilloscope

Some tips to reduce noise:

- Use X1 passive probes
- Enable averaging mode to reduce random noise
- Enable high resolution function if available

Use a minimum of 200 kSa/s (one sample every 5 μ s) to get the correct average current measurement.

5.3 Using an ampere meter for current measurements

An ampere meter can measure the average current flow. This method monitors the current flow by placing the ampere meter in series with the circuit of interest.

Make sure you have prepared the EK as described in [Preparing the nPM1100 EK](#) on page 15.

Connect an ampere meter between the measurement connector for the signal of interest. See [Table 13: Components for current measurement](#) on page 15 for details.

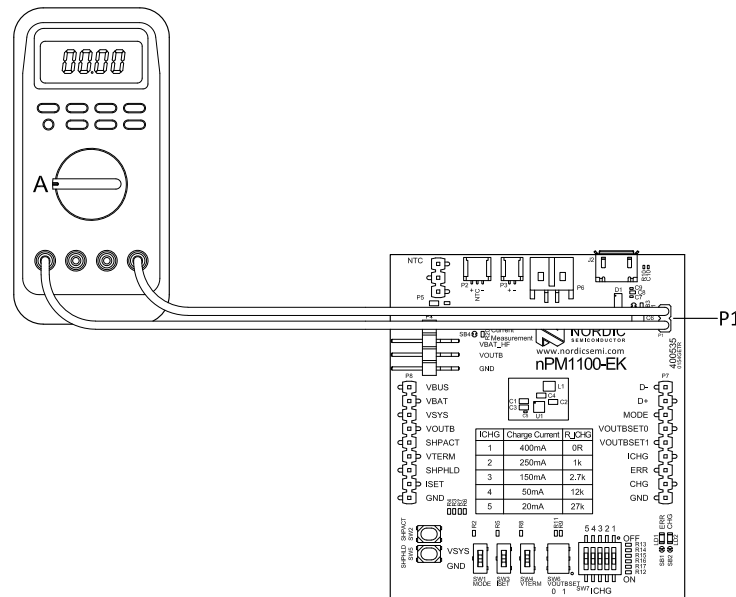

Figure 10: VBUS current measurement with an ampere meter

5.4 Using the Power Profiler Kit II for current measurements

The average and instantaneous current flow can be measured using the PPK2. This is done either with the PPK2 as the power supply for the nPM1100 EK or in series between the nPM1100 EK and the load.

Note: For more information on the PPK2, see the [Power Profiler Kit User Guide](#).

5.4.1 Measuring VBUS current

The PPK2 is operated in Source meter mode for this configuration.

1. Connect the PPK2 to the nPM1100 EK with the 4-pin measurement cable using the following pins:
 - PPK2 **GND** to nPM1100 EK **GND** on either **P7** or **P8** (pin 9)
 - PPK2 **VOUT** to nPM1100 EK **VBUS** on **P8** (pin 1)
2. Connect the load (nRF5340 DK in this example) to **VOUTB** (pin 3) and **GND** (pin 4) on nPM1100 EK **P4**.

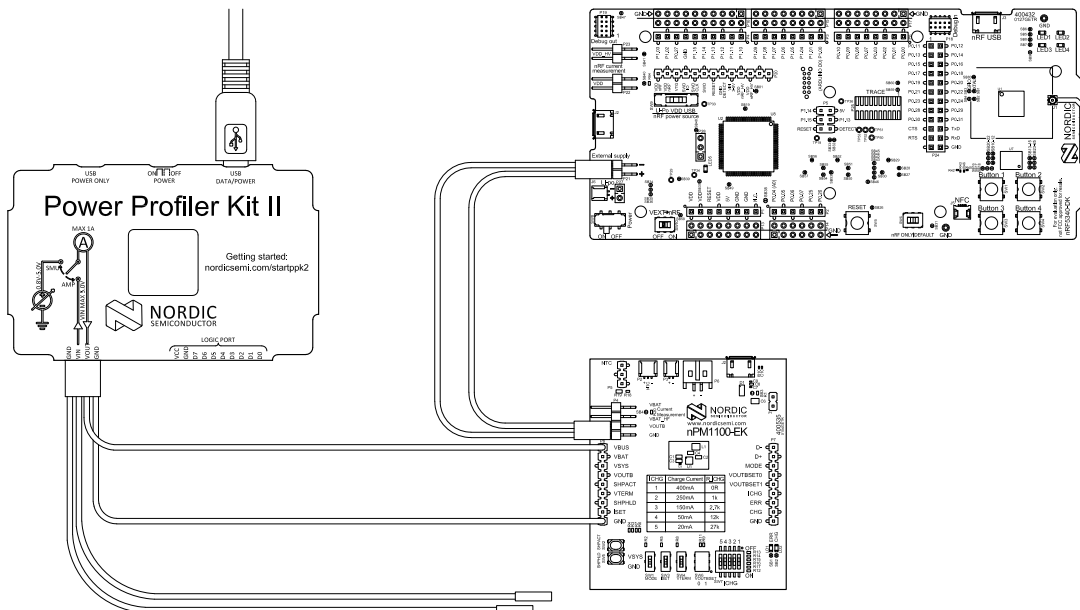

3. Connect the PPK2 to a computer using a USB cable.
4. Start the Power Profiler app.
5. Select your PPK2.
6. Select **Source meter** as the mode.
7. Set the supply voltage to value between 4.5 - 5.0 V.
8. Toggle **Enable power output** to power the nPM1100 EK.
9. Click **Start**.

5.4.2 Measuring VBAT current

The PPK2 is operated in Source meter mode for this configuration.

1. Connect the PPK2 to the nPM1100 EK with the 4-pin measurement cable using the following pins:
 - PPK2 **GND** to nPM1100 EK **GND** on either **P7** or **P8** (pin 9)
 - PPK2 **VOUT** to nPM1100 EK **VBAT_HF** on **P4** (pin 2)
2. Connect the load (nRF5340 DK in this example) to **VOUTB** (pin 3) and **GND** (pin 4) on nPM1100 EK **P4**.

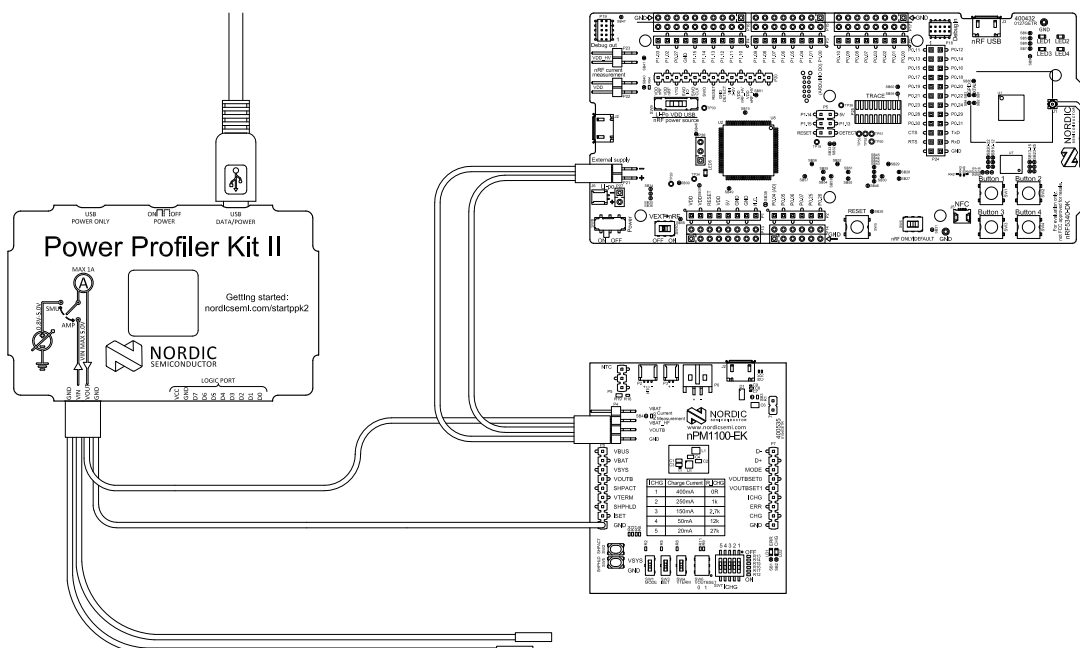

3. Connect the PPK2 to a computer using a USB cable.
4. Start the Power Profiler app.
5. Select your PPK2.
6. Select **Source meter** as the mode.
7. Set the supply voltage to value between 3.0 - 4.35 V.
8. Toggle **Enable power output** to power the nPM1100 EK.
9. Click **Start**.

5.4.3 Measuring VOUTB current

The PPK2 is operated in Ampere meter mode for this configuration.

1. Connect the PPK2 to the nPM1100 EK with a 4-pin measurement cable using the following pins:
 - PPK2 **GND** to nPM1100 EK pin 4 on **P4**
 - PPK2 **VIN** to nPM1100 EK pin 3 on **P4**
 - PPK2 **VOUT** to *Development Kit (DK) External supply*
 - PPK2 **GND** to *DK External supply*

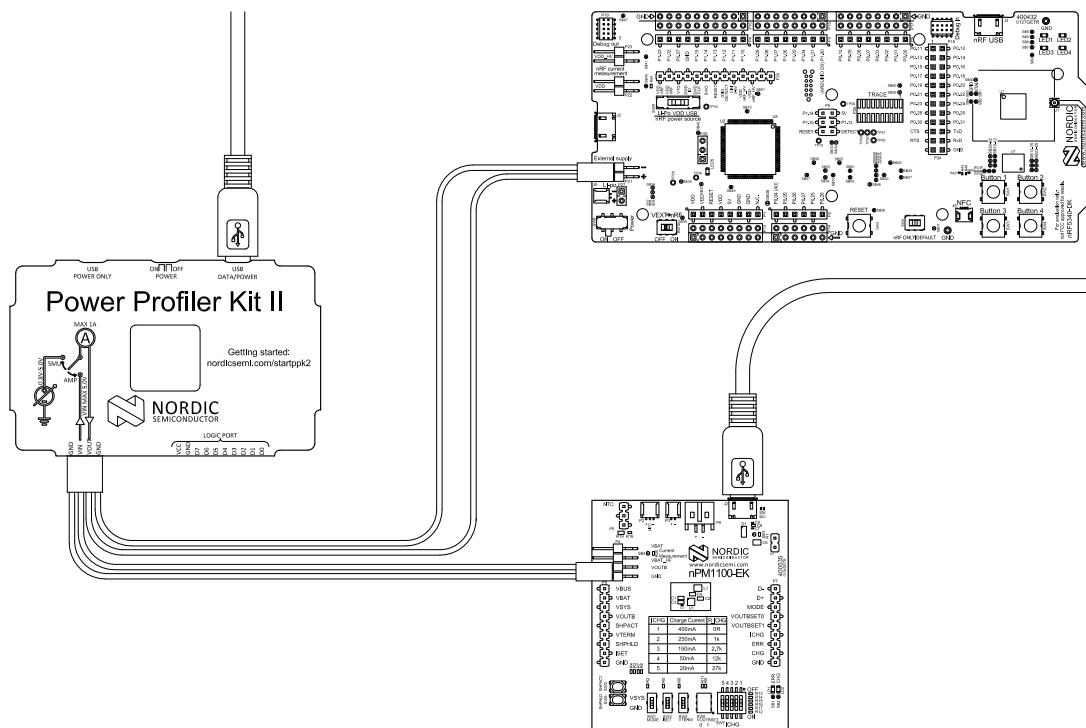

2. Connect the PPK2 to a computer using a USB cable.
3. Connect the nPM1100 EK to a USB power source using a USB cable.
4. Start the Power Profiler app.
5. Select your PPK2.
6. Select **Ampere meter** as the mode.
7. Toggle **Enable power output** to power the target device (nRF5340 DK in this example).
8. Click **Start**.

Glossary

Dedicated Charging Port (DCP)

A downstream port on a device that outputs power through a USB connector but is not capable of enumerating a downstream device.

Development Kit (DK)

A hardware development platform used for application development.

Evaluation Kit (EK)

A platform used to evaluate different development platforms.

Power Management Integrated Circuit (PMIC)

A chip used for various functions related to power management.

Standard Downstream Port (SDP)

A downstream port on a device that complies with the USB 2.0 definition of a host or hub.

Acronyms and abbreviations

These acronyms and abbreviations are used in this document.

DCP

Dedicated Charging Port

DK

Development Kit

EK

Evaluation Kit

PMIC

Power Management Integrated Circuit

SDP

Standard Downstream Port

Recommended reading

In addition to the information in this document, you may need to consult other documents.

Nordic documentation

- [nPM1100 Product Specification](#)
- [nPM1100 EK product page](#)

Legal notices

By using this documentation you agree to our terms and conditions of use. Nordic Semiconductor may change these terms and conditions at any time without notice.

Liability disclaimer

Nordic Semiconductor ASA reserves the right to make changes without further notice to the product to improve reliability, function, or design. Nordic Semiconductor ASA does not assume any liability arising out of the application or use of any product or circuits described herein.

Nordic Semiconductor ASA does not give any representations or warranties, expressed or implied, as to the accuracy or completeness of such information and shall have no liability for the consequences of use of such information. If there are any discrepancies, ambiguities or conflicts in Nordic Semiconductor's documentation, the Product Specification prevails.

Nordic Semiconductor ASA reserves the right to make corrections, enhancements, and other changes to this document without notice.

Life support applications

Nordic Semiconductor products are not designed for use in life support appliances, devices, or systems where malfunction of these products can reasonably be expected to result in personal injury.

Nordic Semiconductor ASA customers using or selling these products for use in such applications do so at their own risk and agree to fully indemnify Nordic Semiconductor ASA for any damages resulting from such improper use or sale.

RoHS and REACH statement

Complete hazardous substance reports, material composition reports and latest version of Nordic's REACH statement can be found on our website www.nordicsemi.com.

Trademarks

All trademarks, service marks, trade names, product names, and logos appearing in this documentation are the property of their respective owners.

Copyright notice

© 2025 Nordic Semiconductor ASA. All rights are reserved. Reproduction in whole or in part is prohibited without the prior written permission of the copyright holder.

